

data referred to : Water; 20°C; 998,3kg/m³; 1,001mm²/s

Tolerances acc. ISO 9906 Grade 2B

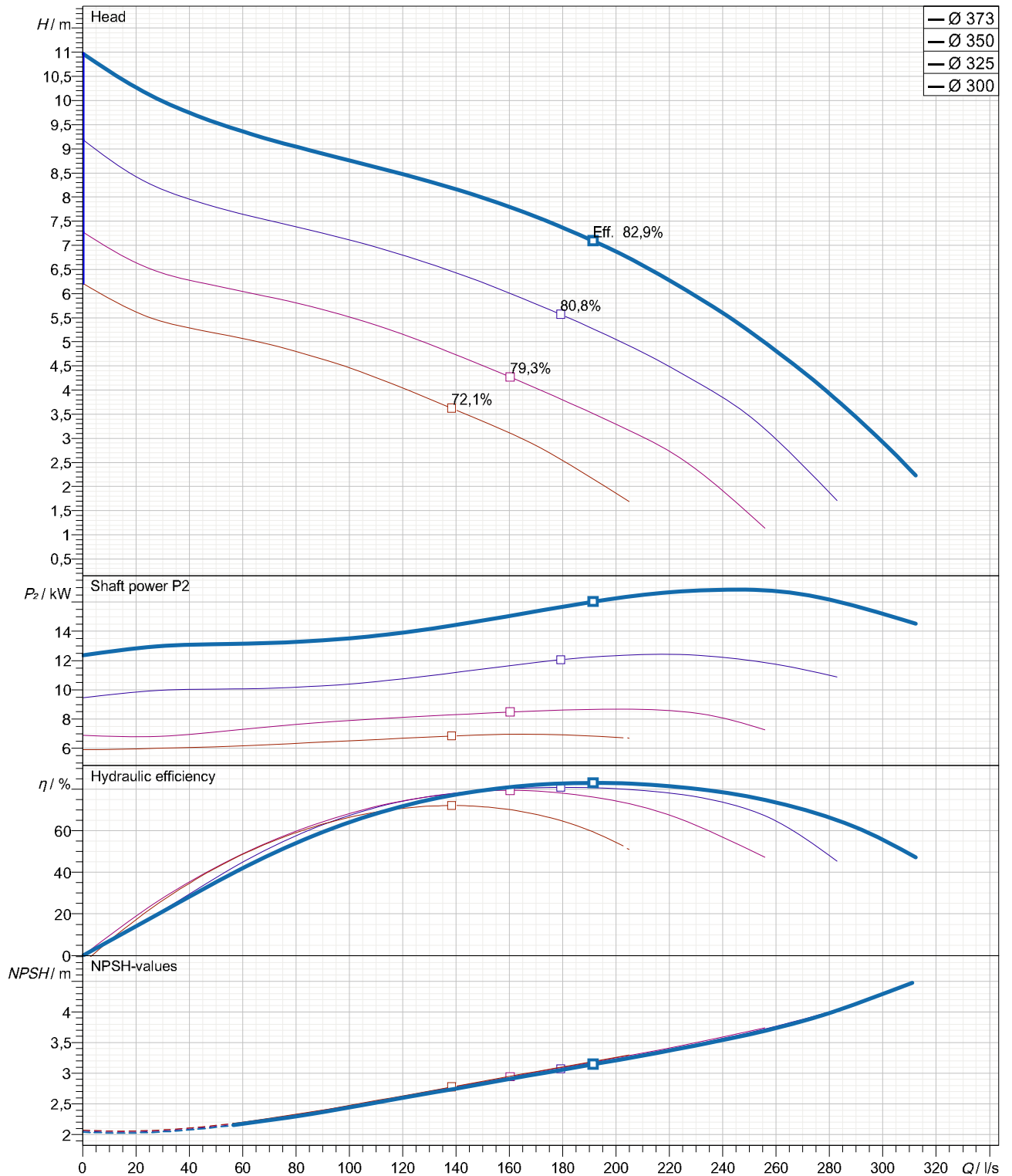

Curves are approximate, pump is guaranteed for one set of conditions (capacity, head, efficiency).

Submersible, centrifugal, non-clogging sewage pump PX4-300.0-8 CHANNEL 1 capable of handling raw,unscreened sewage.

The pumps manufactured within European Union with the latest manufacturing and environmental standards and practical standard features as :

- Dual channel impeller made in ductile iron GGG40 are of non clogging design
- Channel and vortex impellers can be accommodated in the same volute. This advance together with possibility to be trimmed allow to meet changing duties.
- Wear rings with 'reducer' clearances system allow to be re-positioned axially in order to reduce the clearances between the channel impeller and volute.
- Fast lock connection system latch bolts made in stainless steel for easy removal of the motor together with impeller from the volute.

Submersible motor type M4.2B - 18,5 IE2 can be capable of operating continuously in submerged for wet installation. Cooling jacket with Internal cooling system is available as option.

-Electrical motor PXFLOW -SIEMENS standard IE1 or higher efficiency class (IE2 or IE3 as option) have Class H insulation (rated for 180 degrees Celsius) as standard

-Separate sealed terminal connection area

-Rotor shaft oversized made in stainless steel and oversized ball bearings ensuring smooth and vibration free running with extended life time as result.

-Shaft sealing system consist of double mechanical seals built into a replaceable cartridge facilitate quick changes even on-site without special tools.

Motor protections :

- Three thermal overload switches, one per phase, internally wound to combat high temperature loads.
- Built-in moisture sensors to terminal connection area (upper motor side), inside the motor (lower side) and in oil chamber

Materials

PX4-300.0-8 CHANNEL 1 (Dual channel impeller)+18,5 kW

- Motor housing, volute :cast iron GG -25
- Impeller : ductile iron GGG40
- Shaft, cartridge sleeve :stainless steel 431
- Shaft seal:Media side sic/sic
Cooling side sic/sic
- Bearings:upper:single row deep groove ball bearing
lower: double angular contact ball bearing

wet pit installation accesories set (on request)

- Discharge connection bracket (DCB):cast iron GG -25 (standard) or stainless steel (option)
- adapter : ductile iron GGG40 (standard) or stainless steel (option)
- Upper guide bracket (UGB):galvanize steel (standard) or stainless steel (option)

PX4-300.0-8 CHANNEL 1 With motor M4.2B - 18,5 IE2

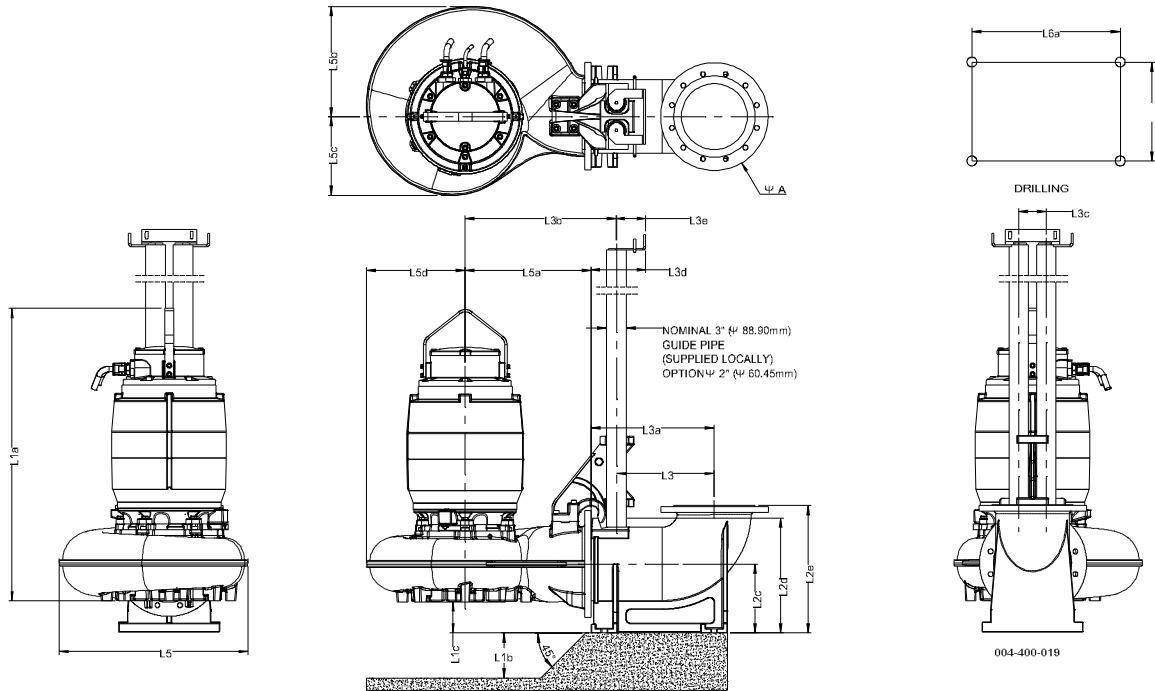

Dimensions	mm	Dimensions	mm
Name	Value	Name	Value
L1a	1332	L5	860
L1b	204	L5a	574
L1c	141	L5b	501
L2c	315	L5c	359
L2d	522,5	L5d	450
L2e	580	L6a	500
L3	446	L6b	330
L3a	561		
L3b	691		
L3c	125		
L3d	248		
L3e	133		

For Discharge connection bracket :
 Outlet flange - Standard : DN300 / PN10- Option :12" ANSI class 125

For pump :
 Outlet flange - Standard : DN300 / PN10- Option :12" ANSI class 125

Suction flange - Standard : DN300 / PN10- Option :12" ANSI class 125

Weight of Pump with cooling jacket = 905 kg
 (without cooling jacket : - 120,2 kg)

Weight of Adapter = 33 kg
 Weight of Discharge connection bracket (DCB) 300 = 186 kg

PX4-300.0-8 CHANNEL 1 With motor M4.2B - 18,5 IE2

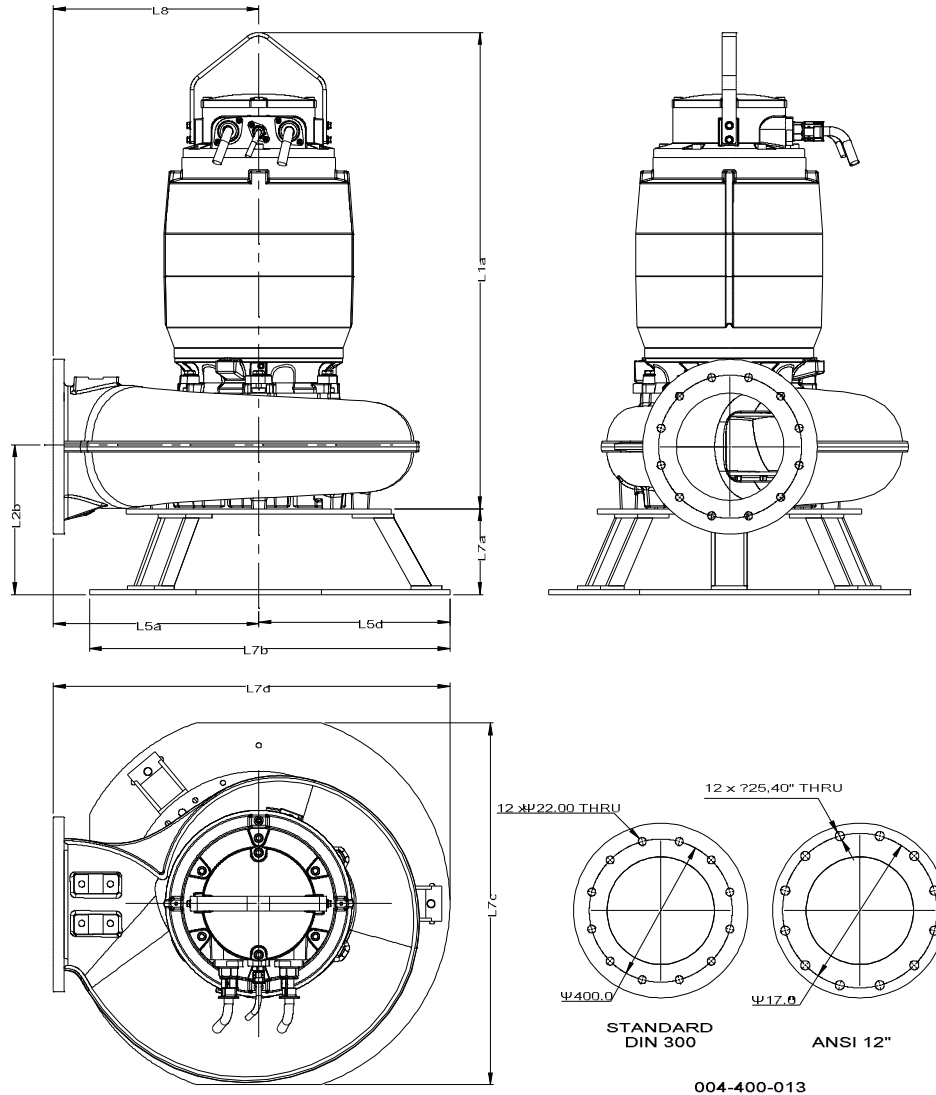

Dimensions		Dimensions	
Name	mm	Name	mm
L1a	1332		
L2b	419		
L5a	473		
L5d	535		
L7a	240		
L7b	1008		
L7c	1012		
L7d	1108		
L8	574		

Outlet for hose - Option : " 300mm (12")

For pump :
Outlet flange - Standard : DN300 / PN10
- Option : 12" ANSI class 125

Suction flange - Standard : DN300 / PN10
- Option : 12" ANSI class 125

Weight of Pump with cooling jacket = 905 kg
(without cooling jacket : - 120,2 kg)
Weight of Base for Transportable = 88 kg

PX4-300.0-8 CHANNEL 1 With motor M4.2B - 18,5 IE2

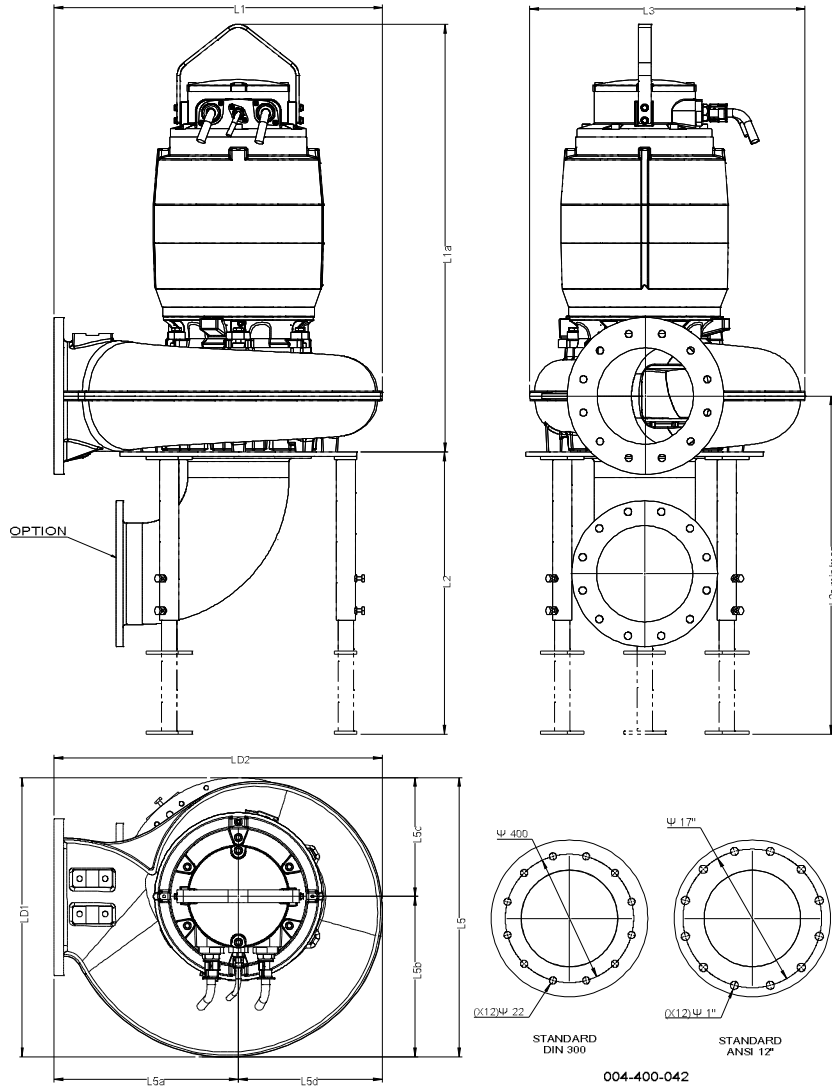

004-400-042

Dimensions	mm	Dimensions	mm
Name	Value	Name	Value
L1	1231	LD2	1023
L1a	1332		
L2	880		
L2a max	1054		
L2a min	804		
L3	859		
L5	870		
L5a	574		
L5b	500		
L5c	370		
L5d	450		
LD1	870		

Outlet flange - Standard : DN300 / PN10
- Option : 12" ANSI class 125

Suction flange - Standard : DN300 / PN10
- Option : 12" ANSI class 125

Weight of Pump with cooling jacket = 905 kg
Weight of Adjustable Legs = 48 kg

PX4-300.0-8 CHANNEL 1 With motor M4.2B - 18,5 IE2

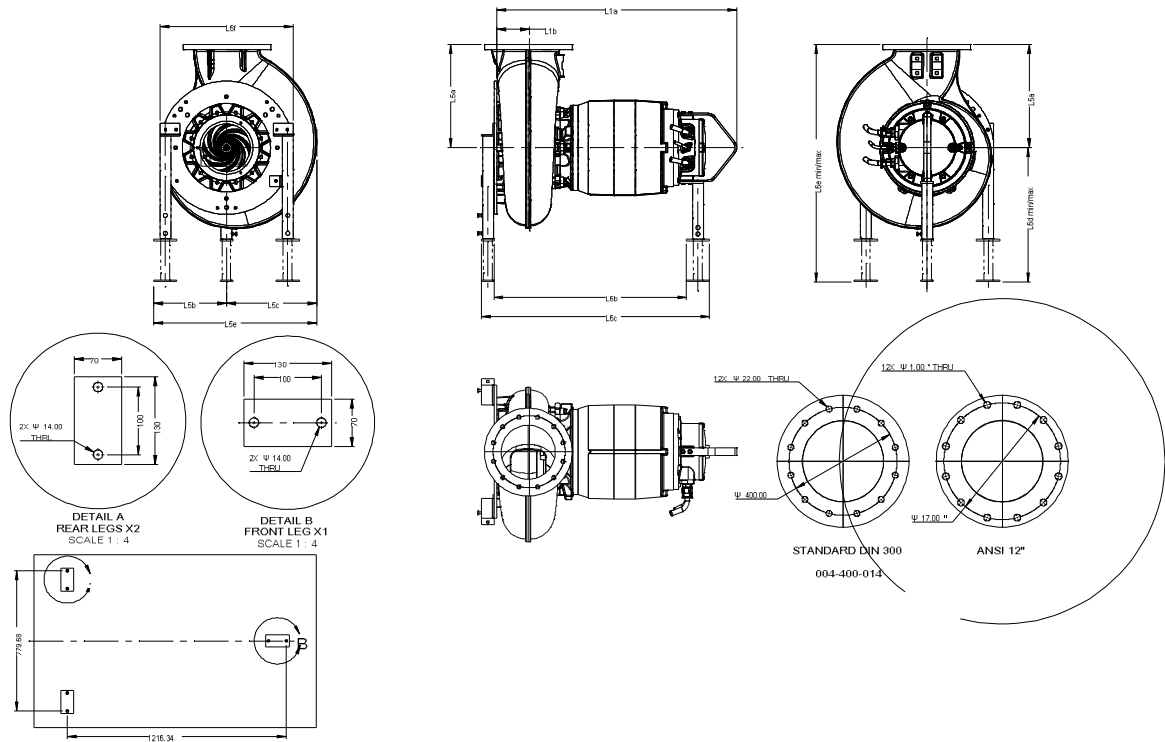

Dimensions	mm	Dimensions	mm	
Name	Value	Name	Value	Outlet flange - Standard : DN300 / PN10 - Option : 12" ANSI class 125 Suction flange - Standard : DN300 / PN10 - Option : 12" ANSI class 125 Weight of Pump with cooling jacket = 905 kg Weight of Adjustable Legs = 45 kg
L1a	1332	L6f	740	
L1b	179			
L5a	574			
L5b	405			
L5c	503			
L5e	908			
L6b	1066			
L6c	1267			
L6dmax	746			
L6dmin	519			
L6emax	1320			
L6emin	1095			