

data referred to : Water; 20°C; 998,3kg/m³; 1,001mm²/s

Tolerances acc. ISO 9906 Grade 2B

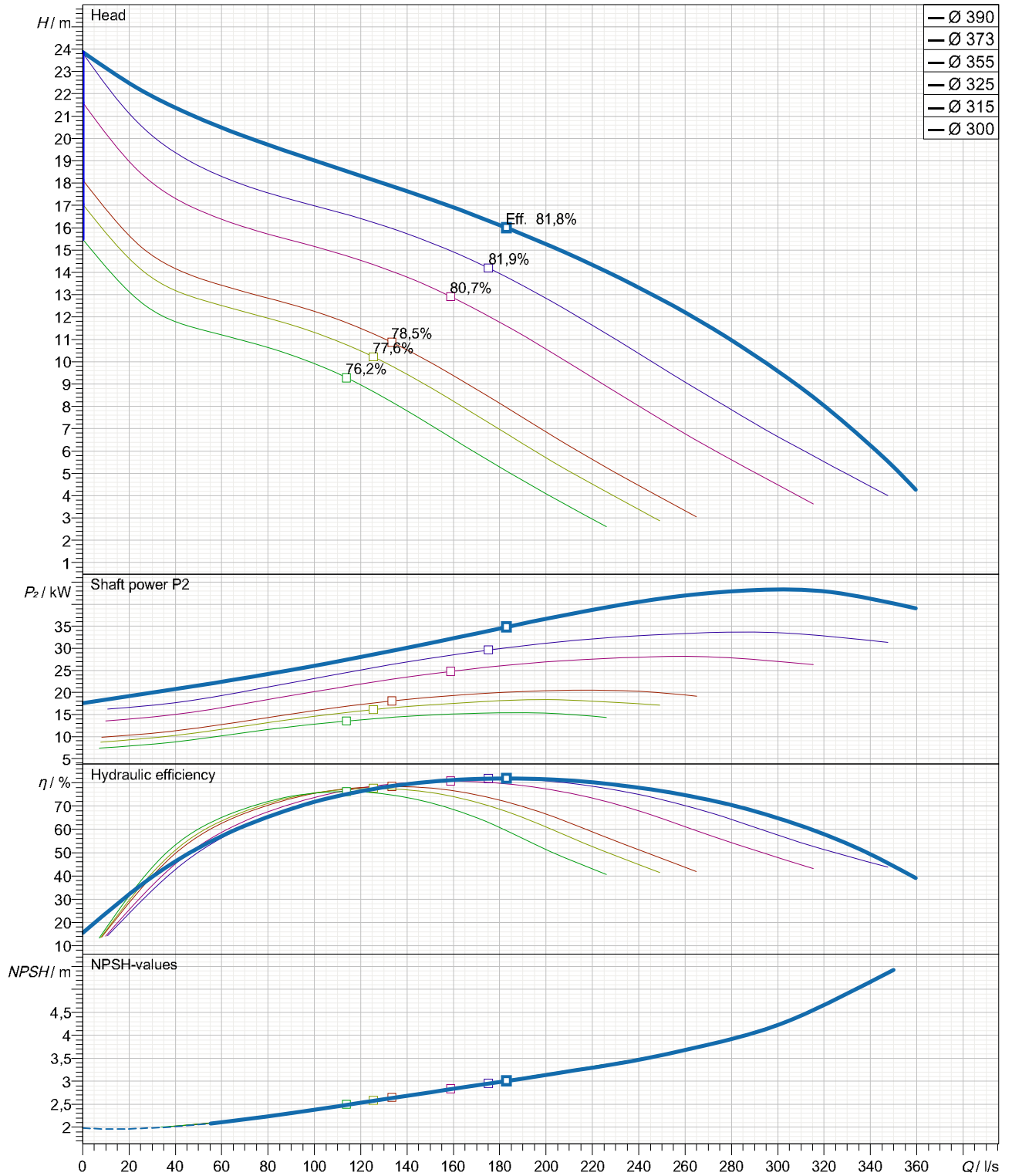

Curves are approximate, pump is guaranteed for one set of conditions (capacity, head, efficiency).

Submersible, centrifugal, non-clogging sewage pump PX4-250.0-6 CHANNEL 1 capable of handling raw,unscreened sewage.

The pumps manufactured within European Union with the latest manufacturing and environmental standards and practical standard features as :

- Dual channel impeller made in ductile iron GGG40 are of non clogging design
- Channel and vortex impellers can be accommodated in the same volute. This advance together with possibility to be trimmed allow to meet changing duties.
- Wear rings with 'reducer' clearances system allow to be re-positioned axially in order to reduce the clearances between the channel impeller and volute.
- Fast lock connection system latch bolts made in stainless steel for easy removal of the motor together with impeller from the volute.

Submersible motor type M4.2C - 45 IE2 can be capable of operating continuously in submerged for wet installation. Cooling jacket with Internal cooling system is available as option.

-Electrical motor PXFLOW -SIEMENS high efficiency class IE2(premium efficiency IE3 as option) have Class H insulation (rated for 180 degrees Celsius)as standard

-Separate sealed terminal connection area

-Rotor shaft oversized made in stainless steel and oversized ball bearings ensuring smooth and vibration free running with extended life time as result.

-Shaft sealing system consist of double mechanical seals built into a replaceable cartridge facilitate quick changes even on-site without special tools.

Motor protections :

- Three thermal overload switches, one per phase, internally wound to combat high temperature loads.
- Built-in moisture sensors to terminal connection area (upper motor side), inside the motor (lower side) and in oil chamber

Materials

PX4-250.0-6 CHANNEL 1 (Dual channel impeller)+45 kW

- Motor housing, volute :cast iron GG -25
- Impeller : ductile iron GGG40
- Shaft, cartridge sleeve :stainless steel 431
- Shaft seal:Media side sic/sic
Cooling side sic/sic
- Bearings:upper:single row deep groove ball bearing
lower: double angular contact ball bearing

wet pit installation accesories set (on request)

- Discharge connection bracket (DCB):cast iron GG -25 (standard) or stainless steel (option)
- adapter : ductile iron GGG40 (standard) or stainless steel (option)
- Upper guide bracket (UGB):galvanize steel (standard) or stainless steel (option)

PX4-250.0-6 CHANNEL 1 With motor M4.2C-45 IE2

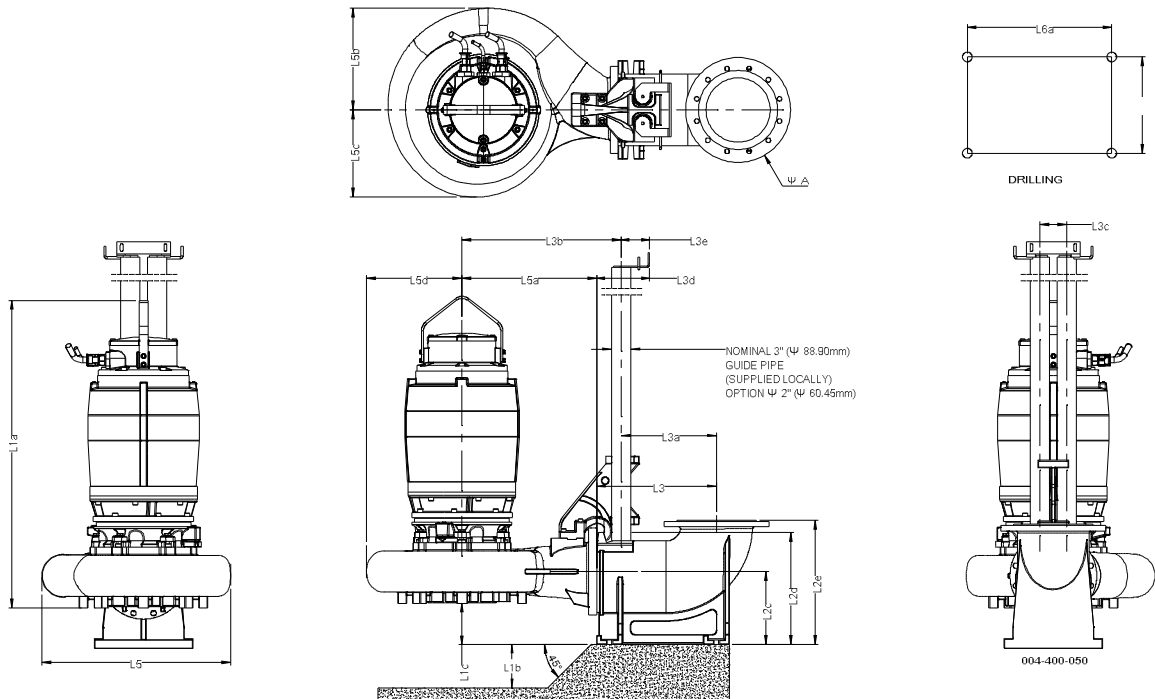

Dimensions		mm	Dimensions		mm
Name	Value		Name	Value	
L1a	1437		L5	883	For Discharge connection bracket : Outlet flange - Standard : DN300 / PN10- Option : 12" ANSI class 125 For pump : Outlet flange - Standard : DN250 / PN10- Option : 10" ANSI class 125 Suction flange - Standard : DN300 / PN10- Option : 12" ANSI class 125 Option : DN250 / PN10- Option : 10" ANSI class 125 Weight of Pump with cooling jacket = 1040 kg (without cooling jacket : - 102 kg) Weight of Adapter = 33 kg Weight of Discharge connection bracket (DCB) 300 = 186 kg
L1b	204		L5a	630	
L1c	190		L5b	476	
L2c	340		L5c	407	
L2d	522,5		L5d	446	
L2e	580		L6a	500	
L3	561		L6b	330	
L3a	446				
L3b	745				
L3c	125				
L3d	248				
L3e	133				

PX4-250.0-6 CHANNEL 1 With motor M4.2C-45 IE2

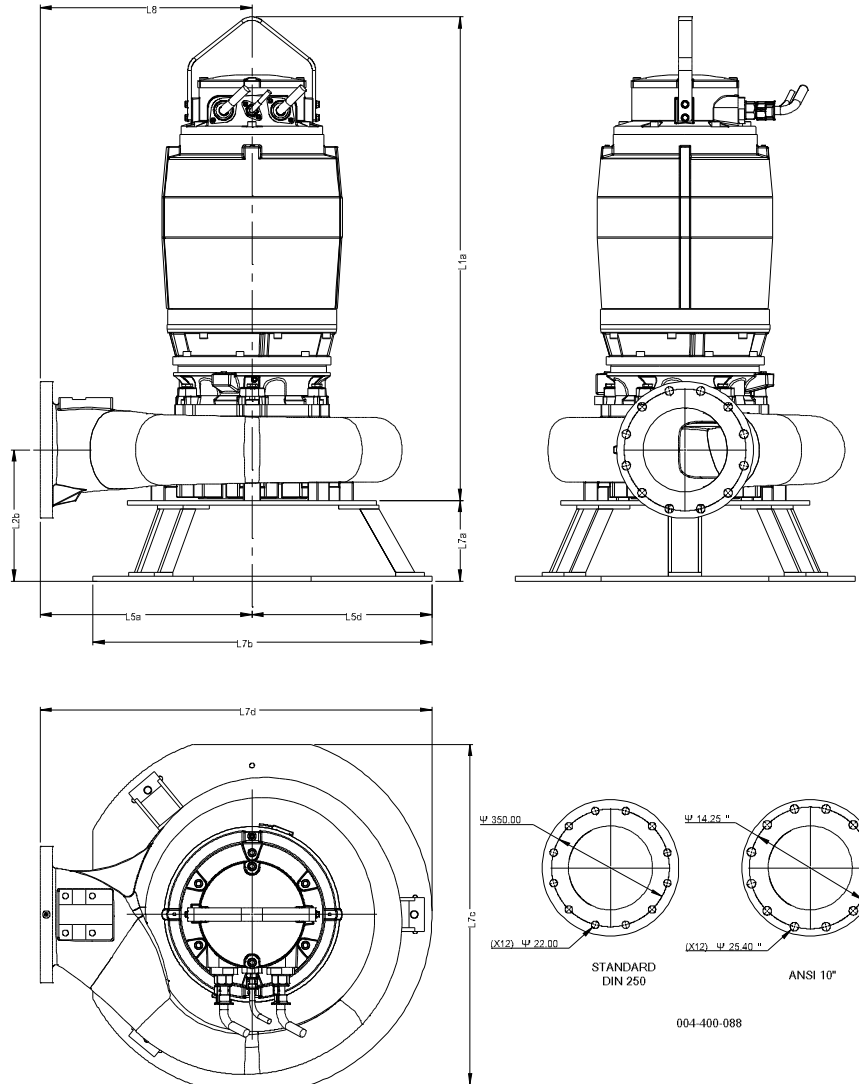

Dimensions	mm	Dimensions	mm
Name	Value	Name	Value
L1a	1437		
L2b	390		
L5a	630		
L5d	535		
L7a	240		
L7b	1008		
L7c	1012		
L7d	1165		
L8	630		

Outlet for hose - Option : " 250mm (10")

For pump :

Outlet flange - Standard : DN250 / PN10
- Option : 10" ANSI class 125

Suction flange - Standard : DN300 / PN10
- Option : 12" ANSI class 125

Weight of Pump with cooling jacket = 1040 kg
(without cooling jacket : - 102 kg)

Weight of Base for Transportable = 88 kg

PX4-250.0-6 CHANNEL 1 With motor M4.2C-45 IE2

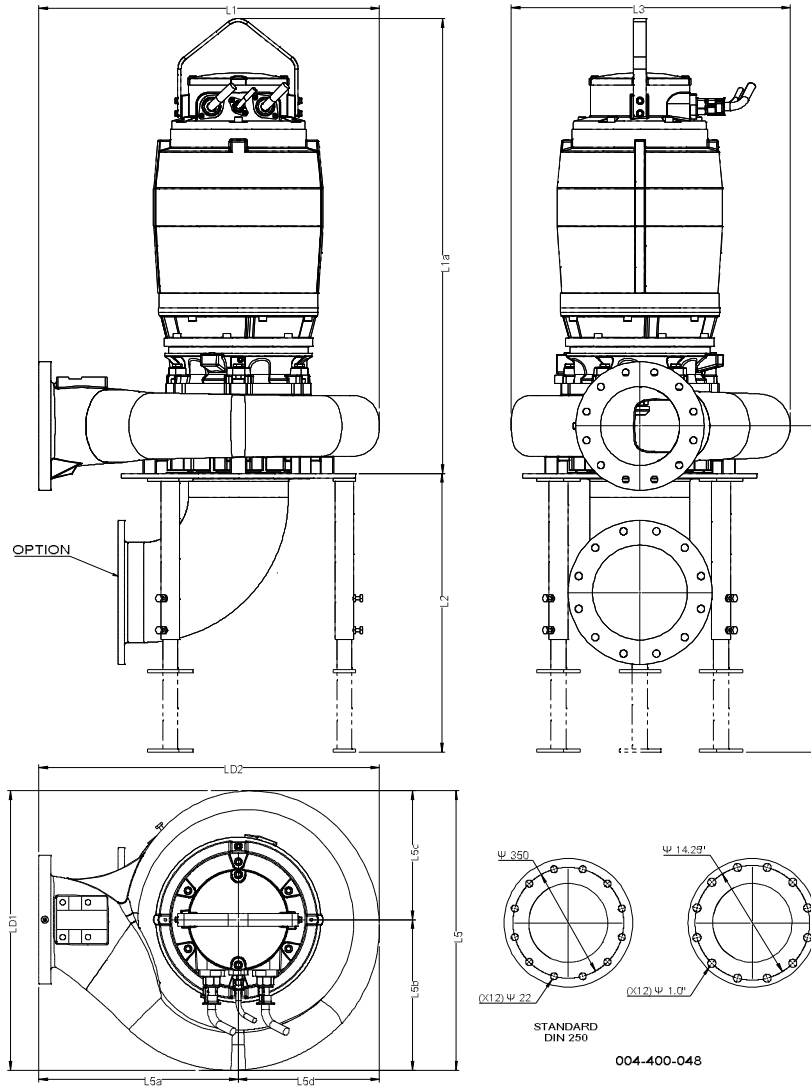

Dimensions	mm	Dimensions	mm
Name	Value	Name	Value
L1	1076	LD2	1076
L1a	1437		
L2	880		
L2a max	1030		
L2a min	780		
L3	883		
L5	883		
L5a	630		
L5b	476		
L5c	407		
L5d	445		
LD1	883		

Outlet flange - Standard : DN250 / PN10
- Option : 10" ANSI class 125

Suction flange - Standard : DN300 / PN10 - Option : 12" ANSI class 125
- Option : DN250 / PN10- Option : 10" ANSI class 125

Weight of Pump with cooling jacket = 1040 kg
Weight of Adjustable Legs = 48 kg

PX4-250.0-6 CHANNEL 1 With motor M4.2C-45 IE2

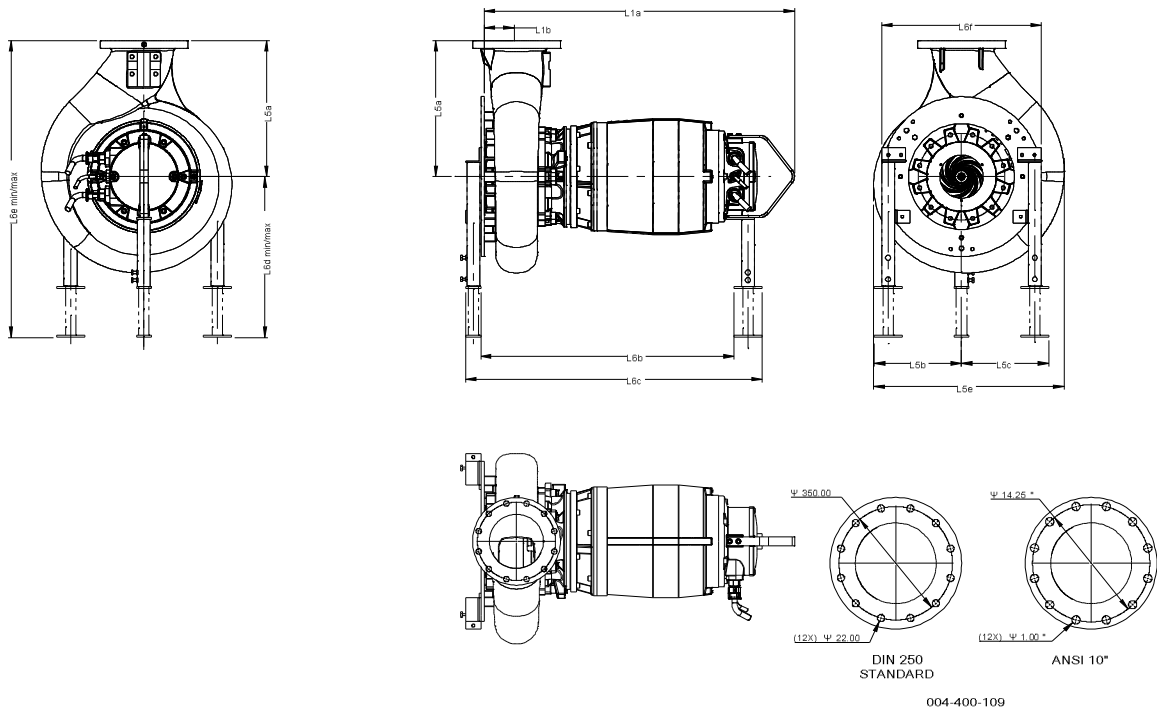

004-400-109

Dimensions		mm	Dimensions		mm
Name	Value		Name	Value	
L1a	1437		L6f	740	Outlet flange - Standard : DN250 / PN10 - Option : 10" ANSI class 125 Suction flange - Standard : DN300 / PN10 - Option : 12" ANSI class 125 - Option : DN250 / PN10- Option : 10" ANSI class 125 Weight of Pump with cooling jacket = 1040 kg Weight of Adjustable Legs = 45 kg
L1b	179				
L5a	574				
L5b	405				
L5c	503				
L5e	908				
L6b	1171				
L6c	1372				
L6dmax	756				
L6dmin	519				
L6emax	1330				
L6emin	1092				