

data referred to : Water; 20°C; 998,3kg/m<sup>3</sup>; 1,001mm<sup>2</sup>/s

Tolerances acc. ISO 9906 Grade 2B

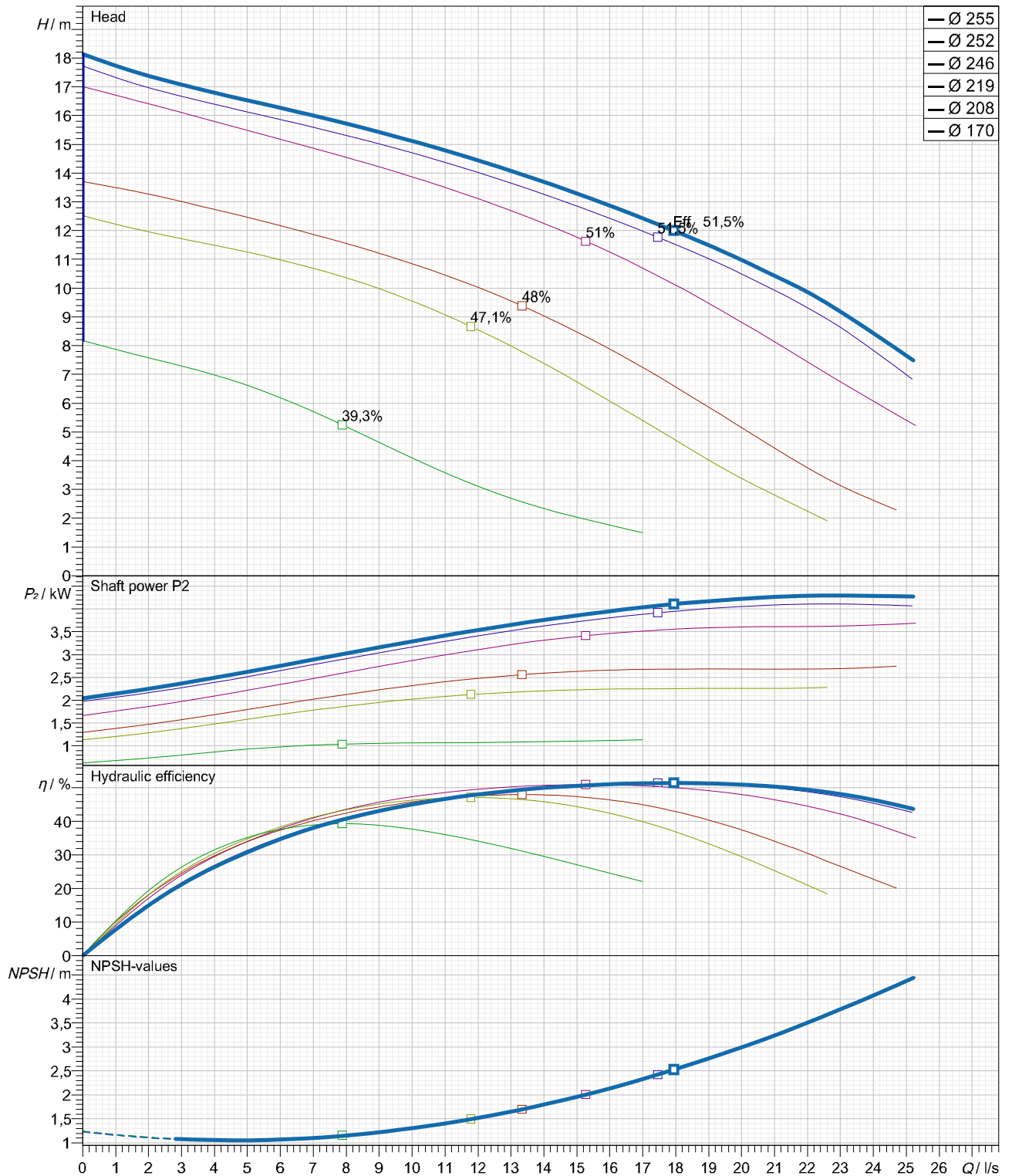

Curves are approximate, pump is guaranteed for one set of conditions (capacity, head, efficiency).

Submersible, centrifugal, non-clogging sewage pump PX3- 80.0-4 VORTEX 1 capable of handling raw,unscreened sewage.

The pumps manufactured within European Union with the latest manufacturing and environmental standards and practical standard features as :

- Vortex impeller made in ductile iron GGG40 are of non clogging design
- Channel and vortex impellers can be accommodated in the same volute. This advance together with possibility to be trimmed allow to meet changing duties.
- Wear rings with 'reducer' clearances system allow to be re-positioned axially in order to reduce the clearances between the channel impeller and volute.
- Fast lock connection system latch bolts made in stainless steel for easy removal of the motor together with impeller from the volute.

Submersible motor type M3.1C- 7,5 can be capable of operating continuously in submerged for wet installation. Cooling jacket with Internal cooling system is available as option.

-Electrical motor PXFLOW -SIEMENS standard IE1 or higher efficiency class (IE2 or IE3 as option) have Class F insulation (rated for 155 degrees Celsius) as standard (Class H as option)

-Separate sealed terminal connection area

-Rotor shaft oversized made in stainless steel and oversized ball bearings ensuring smooth and vibration free running with extended life time as result.

-Shaft sealing system consist of double mechanical seals built into a replaceable cartridge facilitate quick changes even on-site without special tools.

Motor protections :

- Three thermal overload switches, one per phase, internally wound to combat high temperature loads.
- Built-in moisture sensors to terminal connection area (upper motor side), inside the motor (lower side) and in oil chamber

Materials

PX3- 80.0-4 VORTEX 1 ( Vortex impeller )+7,5 kW

- Motor housing, volute :cast iron GG -25
- Impeller : ductile iron GGG40
- Shaft, cartridge sleeve :stainless steel 431
- Shaft seal:Media side sic/sic  
Cooling side carbon/ceramic
- Bearings:upper:single row deep groove ball bearing  
lower: double angular contact ball bearing

wet pit installation accesories set (on request)

- Discharge connection bracket (DCB):cast iron GG -25 (standard) or stainless steel (option)
- adapter : ductile iron GGG40 (standard) or stainless steel (option)
- Upper guide bracket (UGB):galvanize steel (standard) or stainless steel (option)

**PX3- 80.0-4 VORTEX 1 With motor M3.1C-7,5**

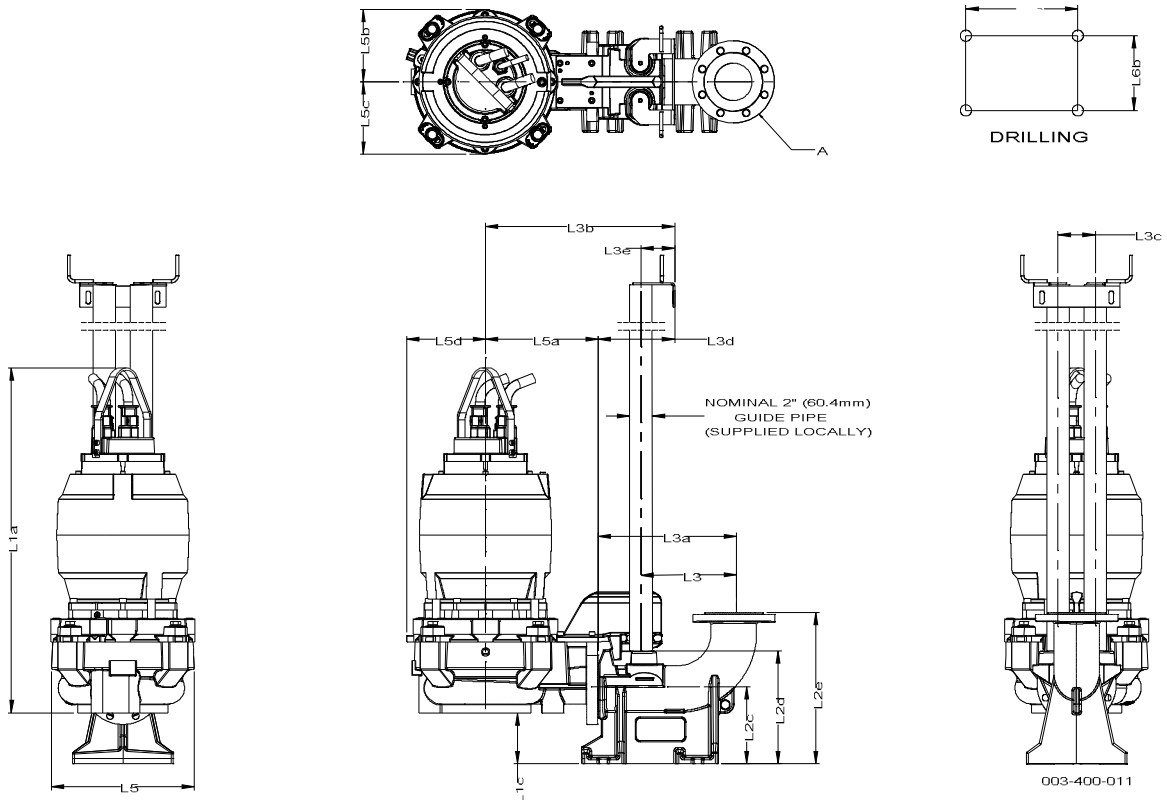

003-400-011

Dimensions mm		Dimensions mm	
Name	Value	Name	Value
L1a	924	L5a	305
L1c	133	L5b	194
L2c	201	L5c	194
L2d	306	L5d	212
L2e	406	L6a	253
L3	256	L6b	140
L3a	370		
L3b	507		
L3c	100		
L3d	206		
L3e	91		
L5	388		

For Discharge connection bracket :  
 Outlet flange - Standard : DN100 / PN10 Flange- Option :4" ANSI class 125  
 - Option : DN80 / PN10 Flange - Option :3" ANSI class 125

For pump :  
 Outlet flange - Standard : DN100 / PN16 -  
 - Option : DN80 / PN16 - Option :3" ANSI class 125  
 Suction flange - Standard : DN100 / PN16 - Option :4" ANSI class 125

Weight of Pump with cooling jacket = 227 kg  
 ( without cooling jacket : -30 kg )  
 Weight of Adapter = 10 kg  
 Weight of Discharge connection bracket (DCB) 100 = 47 kg  
 Weight of Discharge connection bracket (DCB) 80 = 45 kg

**PX3- 80.0-4 VORTEX 1 With motor M3.1C-7,5**

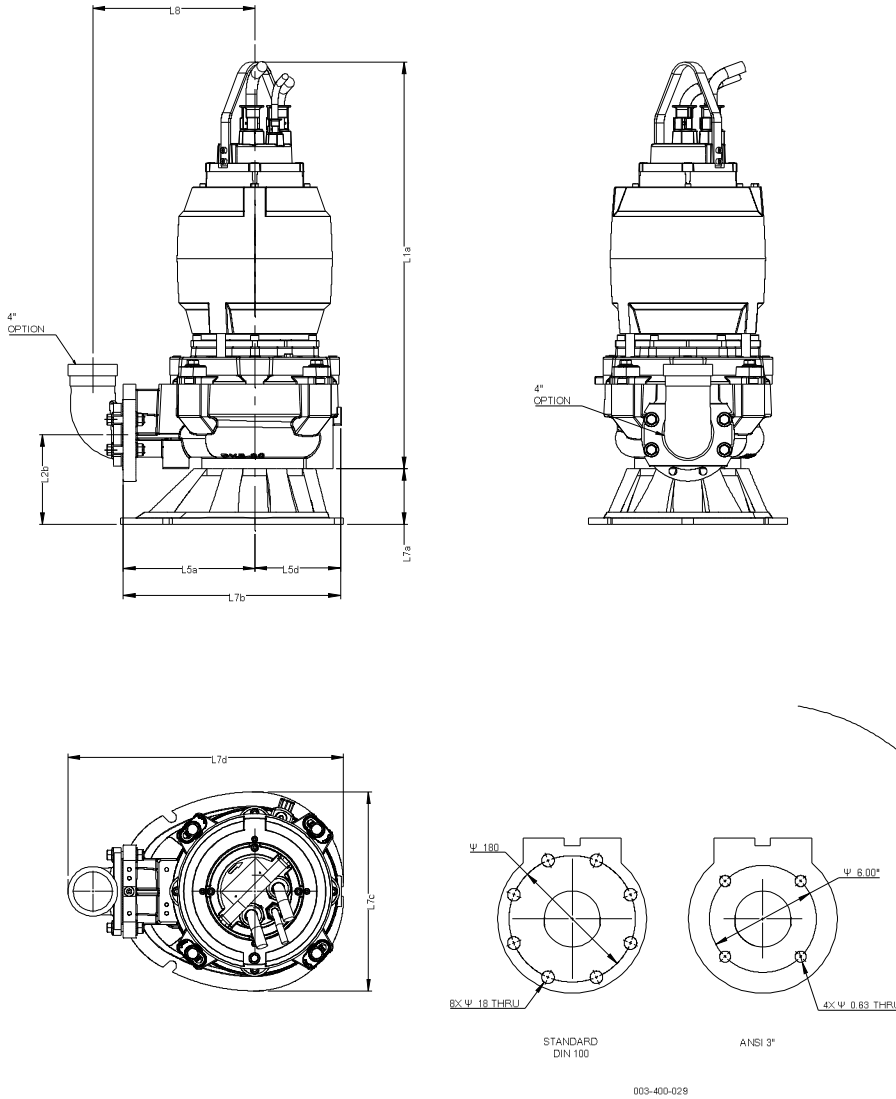

Dimensions		Dimensions	
Name	mm	Name	mm
L1a	924		
L2b	205		
L5a	299,5		
L5d	195,5		
L7a	127		
L7b	495		
L7c	454		
L7d	628		
L8	369		

Outlet for hose - Option : " 100mm (4")  
- Option : " 80mm (3")

For pump :

Outlet flange - Standard : DN100 / PN16  
- Option : DN80 / PN16  
- Option : 3" ANSI class 125

Suction flange - Standard : DN100 / PN16  
- Option : 4" ANSI class 125

Weight of Pump with cooling jacket = 227 kg  
( without cooling jacket : - 30 kg )  
Weight of Base for Transportable = 16,5 kg

**PX3- 80.0-4 VORTEX 1 With motor M3.1C-7,5**

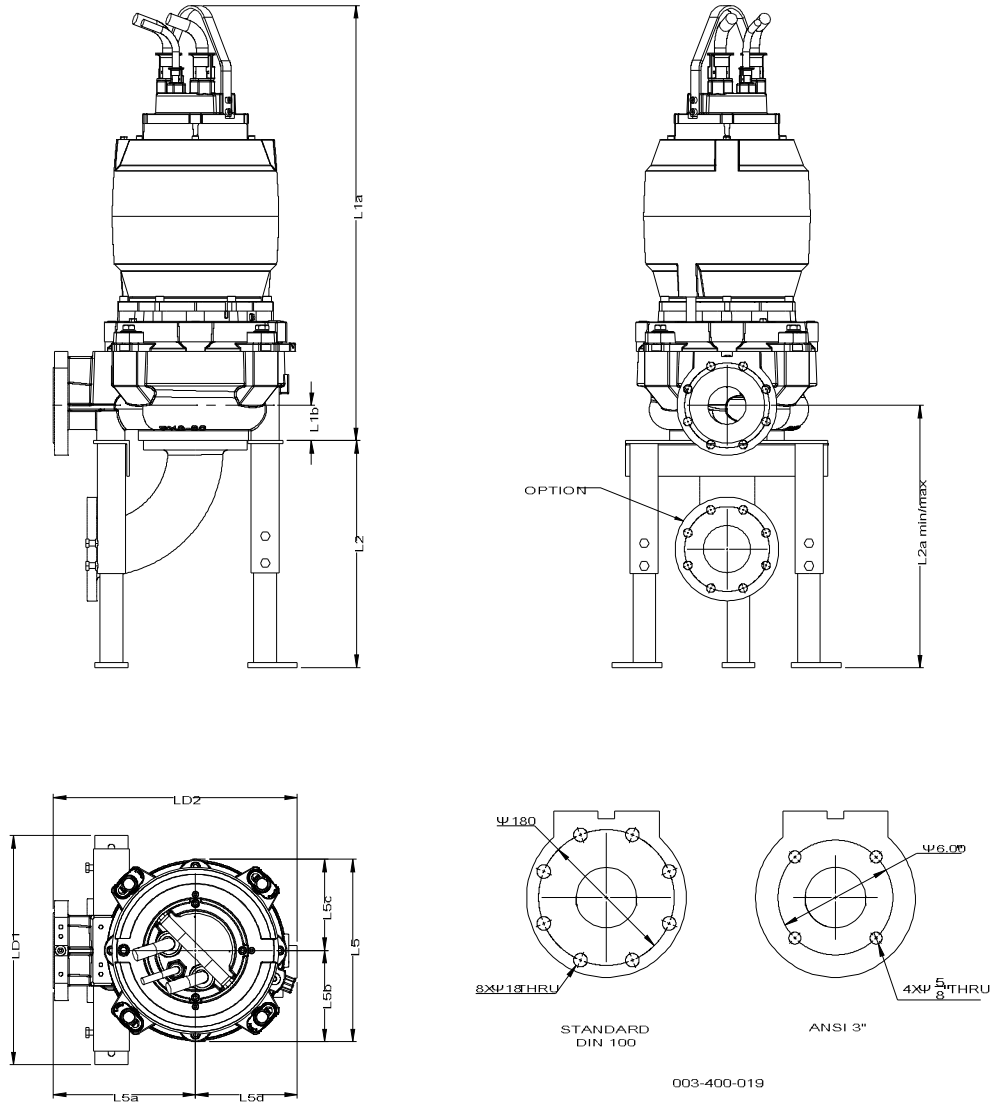

003-400-019

Dimensions	mm	Dimensions	mm
Name	Value	Name	Value
L1a	924	LD2	527,5
L1b	75		
L2 max	481,5		
L2 min	342		
L2a max	557		
L2a min	420		
L5	388		
L5a	301,5		
L5b	194		
L5c	194		
L5d	212		
LD1	511		

Outlet flange - Standard : DN100 / PN16  
 - Option : DN80 / PN16  
 - Option : 3" ANSI class 125

Suction flange - Standard : DN100 / PN16  
 - Option : 4" ANSI class 125

Weight of Pump with cooling jacket = 227 kg  
 Weight of Adjustable Legs = 15,2 kg

**PX3- 80.0-4 VORTEX 1 With motor M3.1C-7,5**

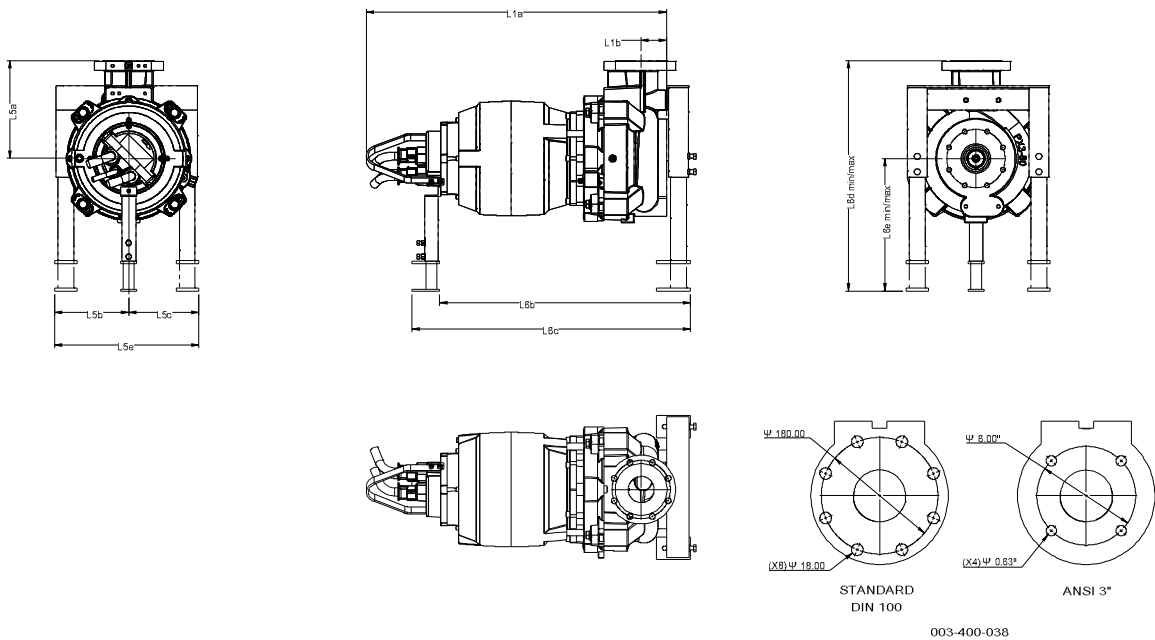

Dimensions	mm	Dimensions	mm
Name	Value	Name	Value
L1a	924		
L1b	78		
L5a	301,5		
L5b	229		
L5c	216		
L5e	445		
L6b	775		
L6c	860		
L6dmax	711		
L6dmin	626		
L6emax	409		
L6emin	324		

Outlet flange - Standard : DN100 / PN16  
 - Option : DN80 / PN16  
 - Option : 3" ANSI class 125

Suction flange - Standard : DN100 / PN16  
 - Option : 4" ANSI class 125

Weight of Pump with cooling jacket = 227 kg  
 Weight of Adjustable Legs = 15,2 kg