

data referred to : Water; 20°C; 998,3kg/m³; 1,001mm²/s

Tolerances acc. ISO 9906 Grade 2B

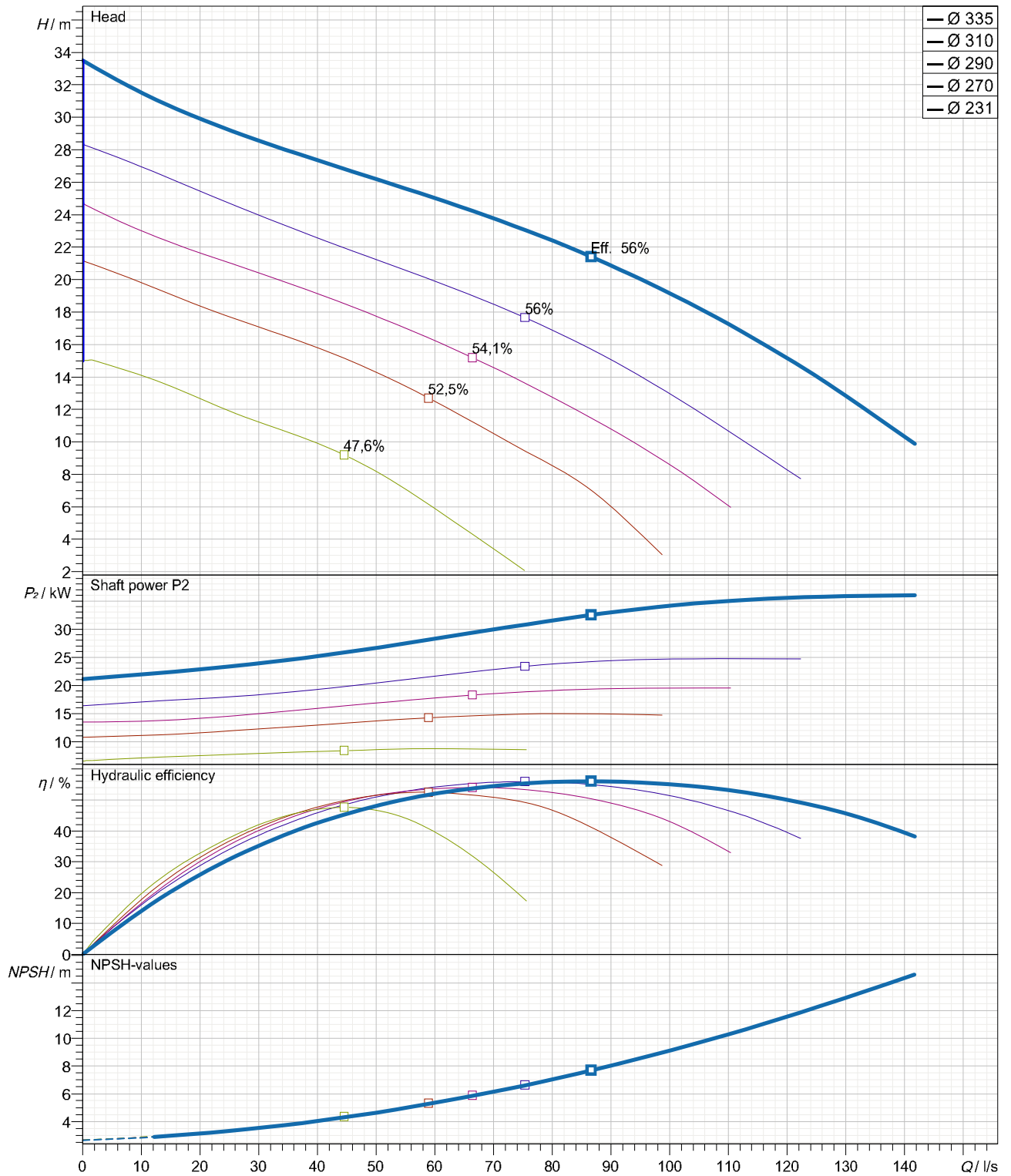

Curves are approximate, pump is guaranteed for one set of conditions (capacity, head, efficiency).

Submersible, centrifugal, non-clogging sewage pump PX3-150.0-4 VORTEX 1 capable of handling raw,unscreened sewage.

The pumps manufactured within European Union with the latest manufacturing and environmental standards and practical standard features as :

- Vortex impeller made in ductile iron GGG40 are of non clogging design
- Channel and vortex impellers can be accommodated in the same volute. This advance together with possibility to be trimmed allow to meet changing duties.
- Wear rings with 'reducer' clearances system allow to be re-positioned axially in order to reduce the clearances between the channel impeller and volute.
- Fast lock connection system latch bolts made in stainless steel for easy removal of the motor together with impeller from the volute.

Submersible motor type M3.1E - 37 can be capable of operating continuously in submerged for wet installation. Cooling jacket with Internal cooling system is available as option.

-Electrical motor PXFLOW -SIEMENS standard IE1 or higher efficiency class (IE2as option) have Class H insulation (rated for 180 degrees Celsius) as standard

-Separate sealed terminal connection area

-Rotor shaft oversized made in stainless steel and oversized ball bearings ensuring smooth and vibration free running with extended life time as result.

-Shaft sealing system consist of double mechanical seals built into a replaceable cartridge facilitate quick changes even on-site without special tools.

Motor protections :

- Three thermal overload switches, one per phase, internally wound to combat high temperature loads.
- Built-in moisture sensors to terminal connection area (upper motor side), inside the motor (lower side) and in oil chamber

Materials

PX3-150.0-4 VORTEX 1 (Vortex impeller)+37 kW

- Motor housing, volute :cast iron GG -25
- Impeller : ductile iron GGG40
- Shaft, cartridge sleeve :stainless steel 431
- Shaft seal:Media side sic/sic
Cooling side sic/sic
- Bearings:upper:single row deep groove ball bearing
lower: double angular contact ball bearing

wet pit installation accesories set (on request)

- Discharge connection bracket (DCB):cast iron GG -25 (standard) or stainless steel (option)
- adapter : ductile iron GGG40 (standard) or stainless steel (option)
- Upper guide bracket (UGB):galvanize steel (standard) or stainless steel (option)

PX3-150.0-4 VORTEX 1 With motor M3.1E-37

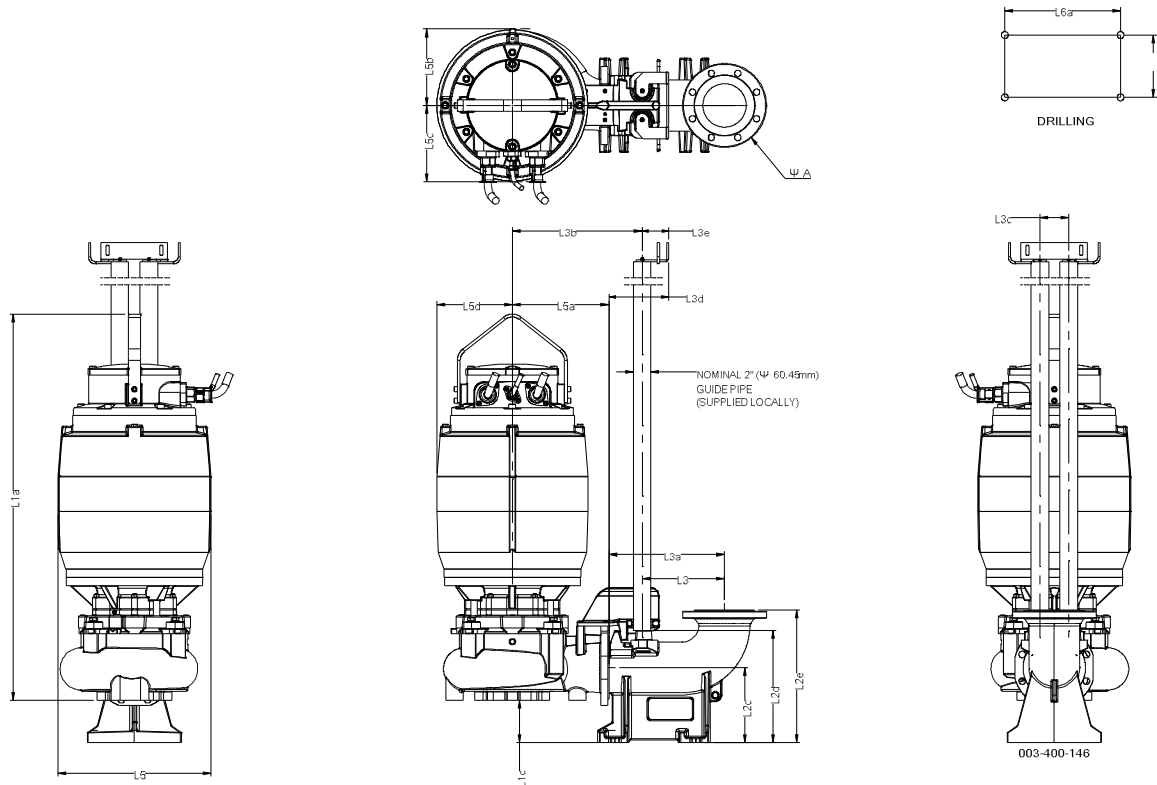

Dimensions	mm	Dimensions	mm
Name	Value	Name	Value
L1a	1335	L5a	333
L1c	153	L5b	265
L2c	260	L5c	265
L2d	388,5	L5d	261
L2e	460	L6a	280
L3	285	L6b	203,6
L3a	400		
L3b	539		
L3c	100		
L3d	206		
L3e	91		
L5	530		

For Discharge connection bracket :
 Outlet flange - Standard : DN150 / PN10- Option : 6" ANSI class 125

For pump :
 Outlet flange - Standard : DN150 / PN16- Option : 6" ANSI class 125
 Suction flange - Standard : DN150 / PN16 - Option : 6" ANSI class 125

Weight of Pump with cooling jacket = 577,4 kg
 (without cooling jacket : - 132,7 kg)
 Weight of Adapter = 10 kg
 Weight of Discharge connection bracket (DCB) 150 = 67

PX3-150.0-4 VORTEX 1 With motor M3.1E-37

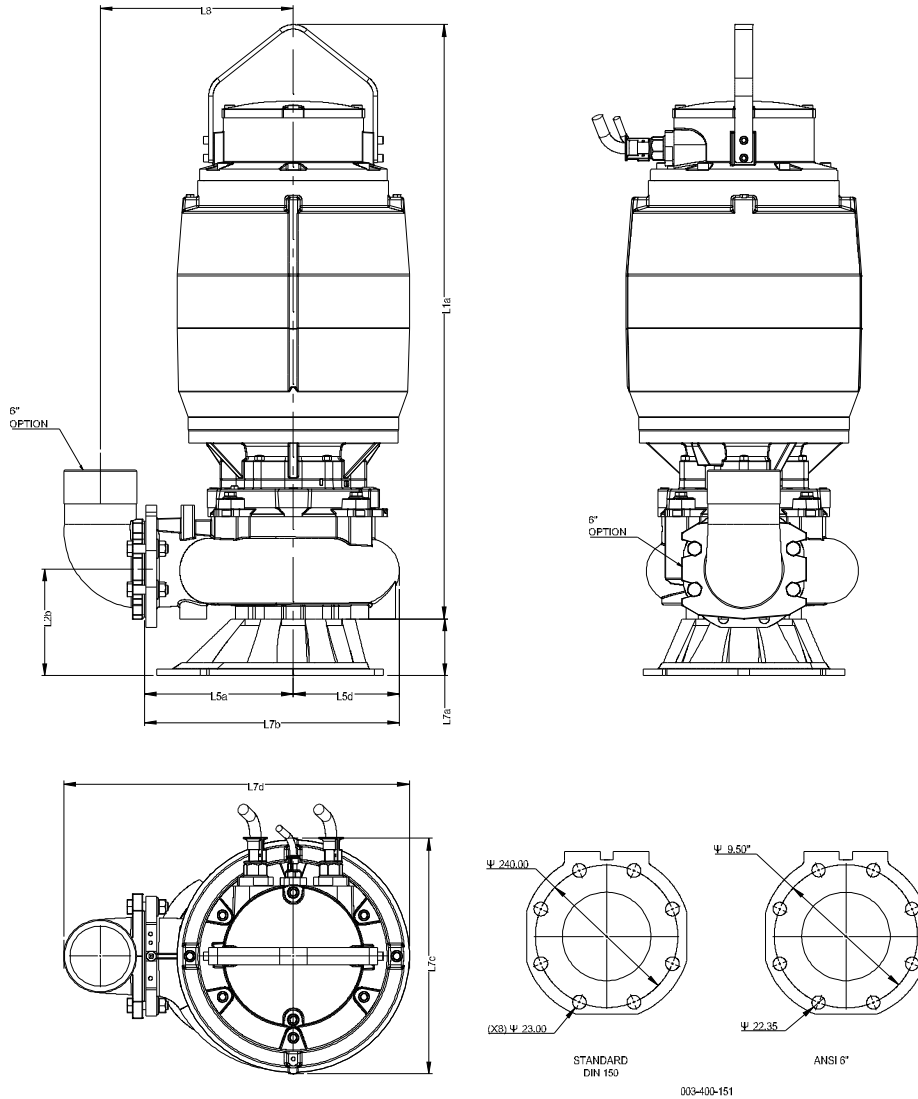

Dimensions		Dimensions	
Name	mm	Name	mm
L1a	1335		
L2b	239		
L5a	334		
L5d	239		
L7a	127		
L7b	573		
L7c	529		
L7d	777		
L8	334		

Outlet for hose - Option : " 150mm (6")

For pump :

Outlet flange - Standard : DN150 / PN16
- Option : 6" ANSI class 125

Suction flange - Standard : DN150 / PN16
- Option : 6" ANSI class 125

Weight of Pump with cooling jacket = 577,4 kg
(without cooling jacket : - 132,7 kg)

Weight of Base for Transportable = 16,5 kg

PX3-150.0-4 VORTEX 1 With motor M3.1E-37

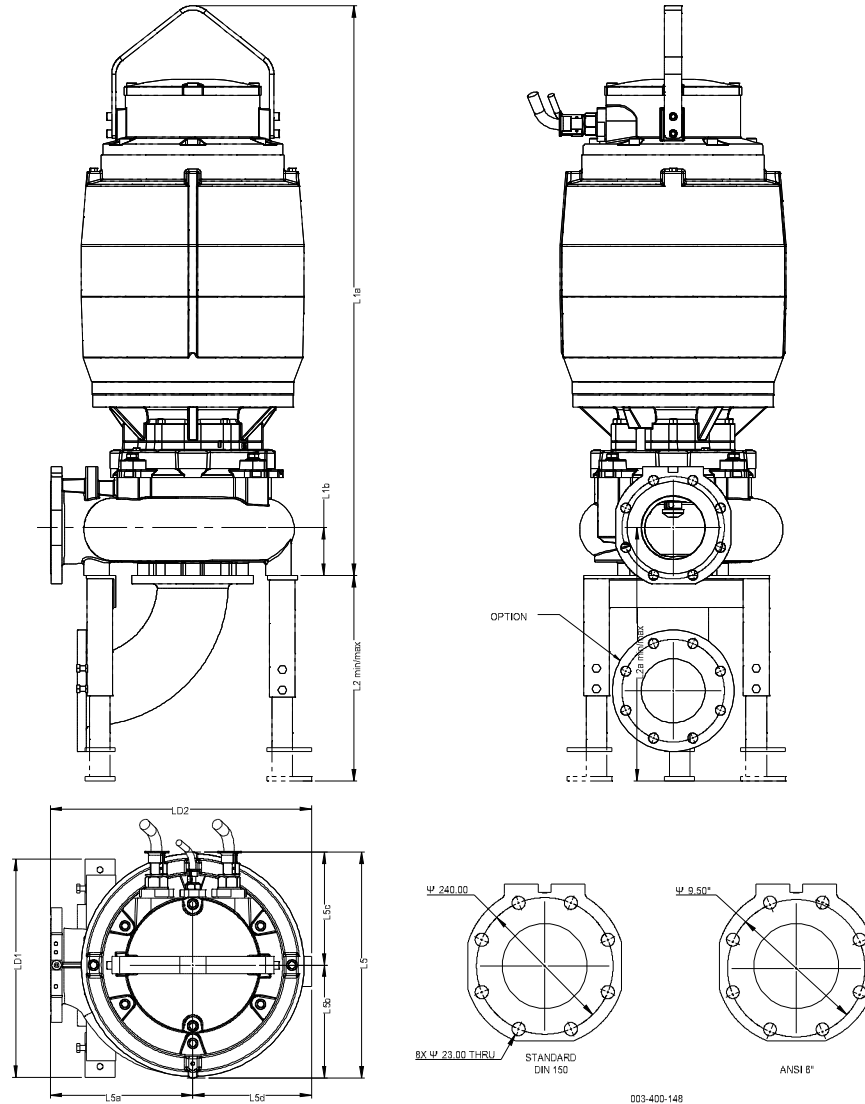

Dimensions	mm	Dimensions	mm
Name	Value	Name	Value
L1a	1335	LD2	612
L1b	112		
L2 max	481,5		
L2 min	413		
L2a max	593		
L2a min	525		
L5	530		
L5a	334		
L5b	265		
L5c	265		
L5d	241		
LD1	511		

Outlet flange - Standard : DN150 / PN16
 - Option : 6" ANSI class 125

Suction flange - Standard : DN150 / PN16
 - Option : 6" ANSI class 125

Weight of Pump with cooling jacket = 577,4 kg
 Weight of Adjustable Legs = 15,2 kg

PX3-150.0-4 VORTEX 1 With motor M3.1E-37

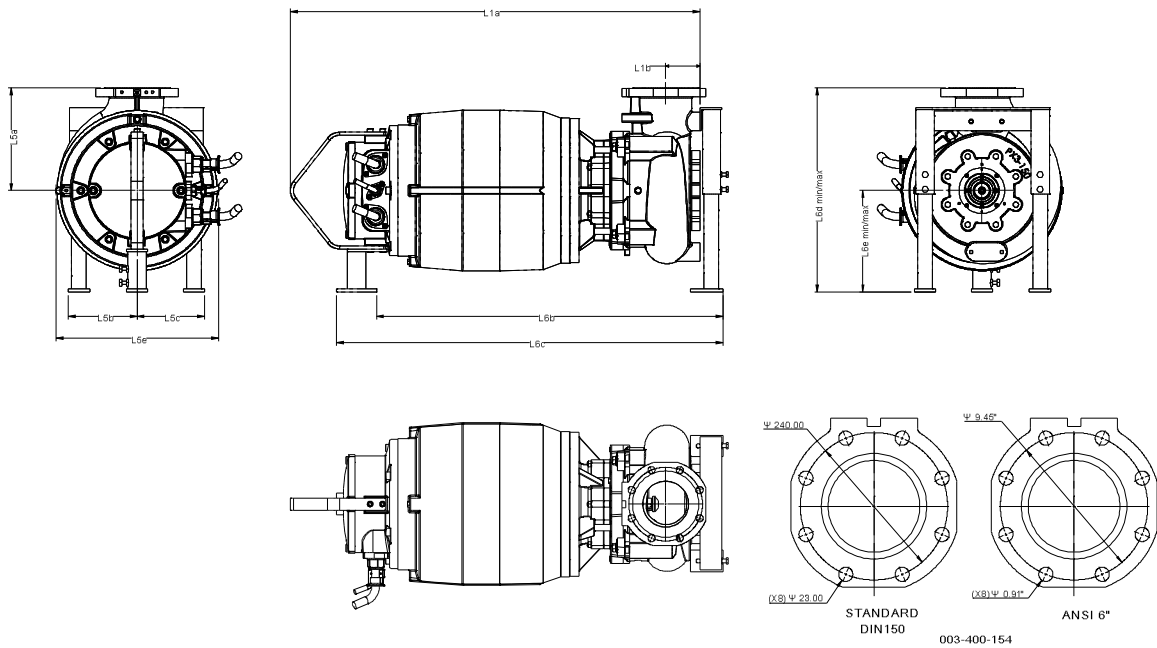

Dimensions	mm	Dimensions	mm
Name	Value	Name	Value
L1	1335		
L1b	90		
L5a	334		
L5b	225		
L5c	220		
L5e	500		
L6b	1129		
L6c	1260		
L6dmax	704		
L6dmin	664		
L6emax	370		
L6emin	330		

Outlet flange - Standard : DN150 / PN16
- Option : 6" ANSI class 125

Suction flange - Standard : DN150 / PN16
- Option : 6" ANSI class 125

Weight of Pump with cooling jacket = 577,4 kg
Weight of Adjustable Legs = 15,2 kg