

data referred to : Water; 20°C; 998,3kg/m³; 1,001mm²/s

Tolerances acc. ISO 9906 Grade 2B

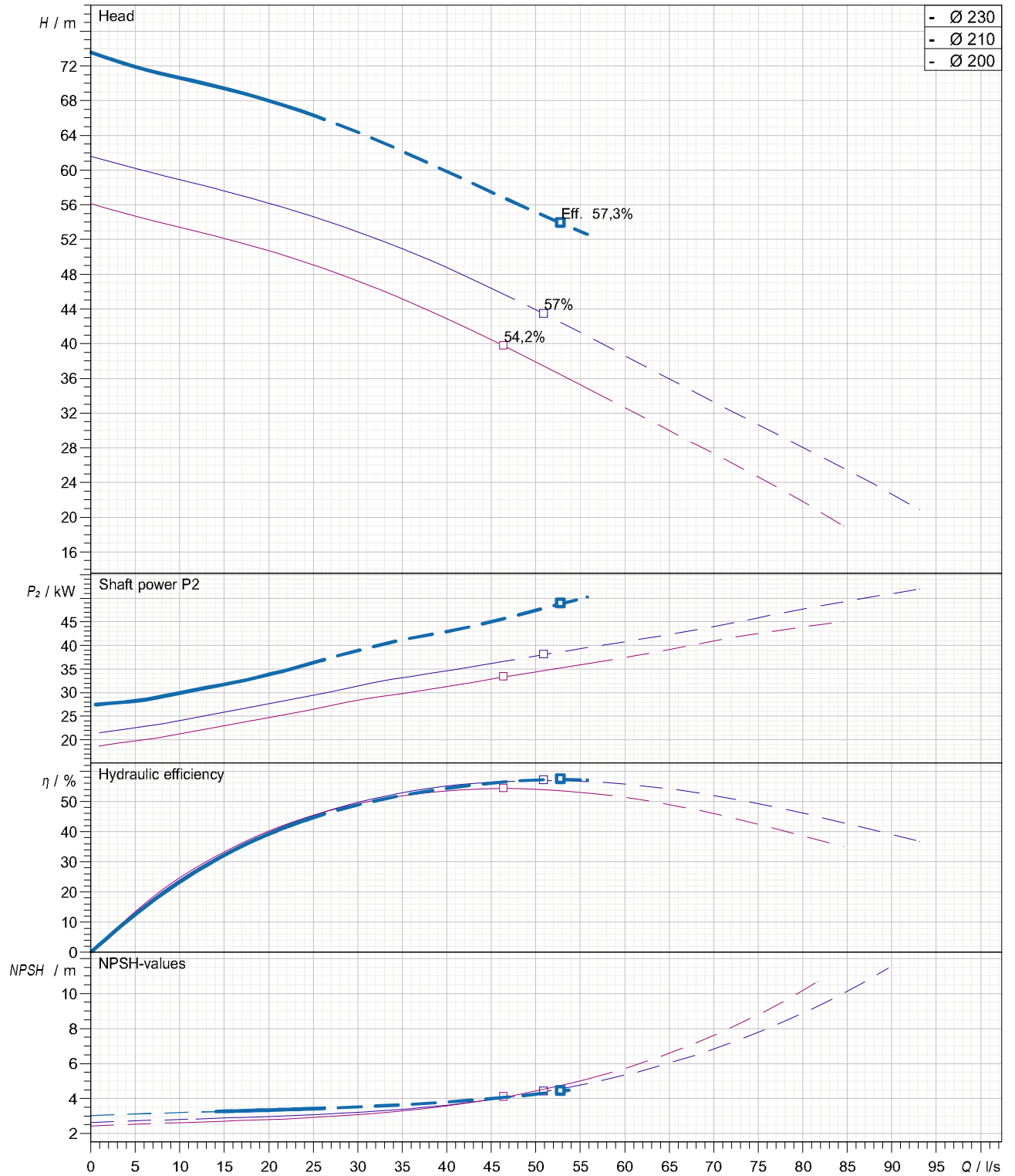

Curves are approximate, pump is guaranteed for one set of conditions (capacity, head, efficiency).

Submersible, centrifugal, non-clogging sewage pump PX3-100.0-2 VORTEX 1 capable of handling raw,unscreened sewage.

The pumps manufactured within European Union with the latest manufacturing and environmental standards and practical standard features as :

- Vortex impeller made in ductile iron GGG40 are of non clogging design
- Channel and vortex impellers can be accommodated in the same volute. This advance together with possibility to be trimmed allow to meet changing duties.
- Wear rings with 'reducer' clearances system allow to be re-positioned axially in order to reduce the clearances between the channel impeller and volute.
- Fast lock connection system latch bolts made in stainless steel for easy removal of the motor together with impeller from the volute.

Submersible motor type M3.1E - 37 can be capable of operating continuously in submerged for wet installation. Cooling jacket with Internal cooling system is available as option.

-Electrical motor PXFLOW -SIEMENS standard IE1 or higher efficiency class (IE2as option) have Class H insulation (rated for 180 degrees Celsius) as standard

-Separate sealed terminal connection area

-Rotor shaft oversized made in stainless steel and oversized ball bearings ensuring smooth and vibration free running with extended life time as result.

-Shaft sealing system consist of double mechanical seals built into a replaceable cartridge facilitate quick changes even on-site without special tools.

Motor protections :

- Three thermal overload switches, one per phase, internally wound to combat high temperature loads.
- Built-in moisture sensors to terminal connection area (upper motor side), inside the motor (lower side) and in oil chamber

Materials

PX3-100.0-2 VORTEX 1 (Vortex impeller)+37 kW

- Motor housing, volute :cast iron GG -25
- Impeller : ductile iron GGG40
- Shaft, cartridge sleeve :stainless steel 431
- Shaft seal:Media side sic/sic
Cooling side sic/sic
- Bearings:upper:single row deep groove ball bearing
lower: double angular contact ball bearing

wet pit installation accessories set (on request)

- Discharge connection bracket (DCB):cast iron GG -25 (standard) or stainless steel (option)
- adapter : ductile iron GGG40 (standard) or stainless steel (option)
- Upper guide bracket (UGB):galvanize steel (standard) or stainless steel (option)

PX3-100.0-2 VORTEX 1 With motor M3.1E - 37

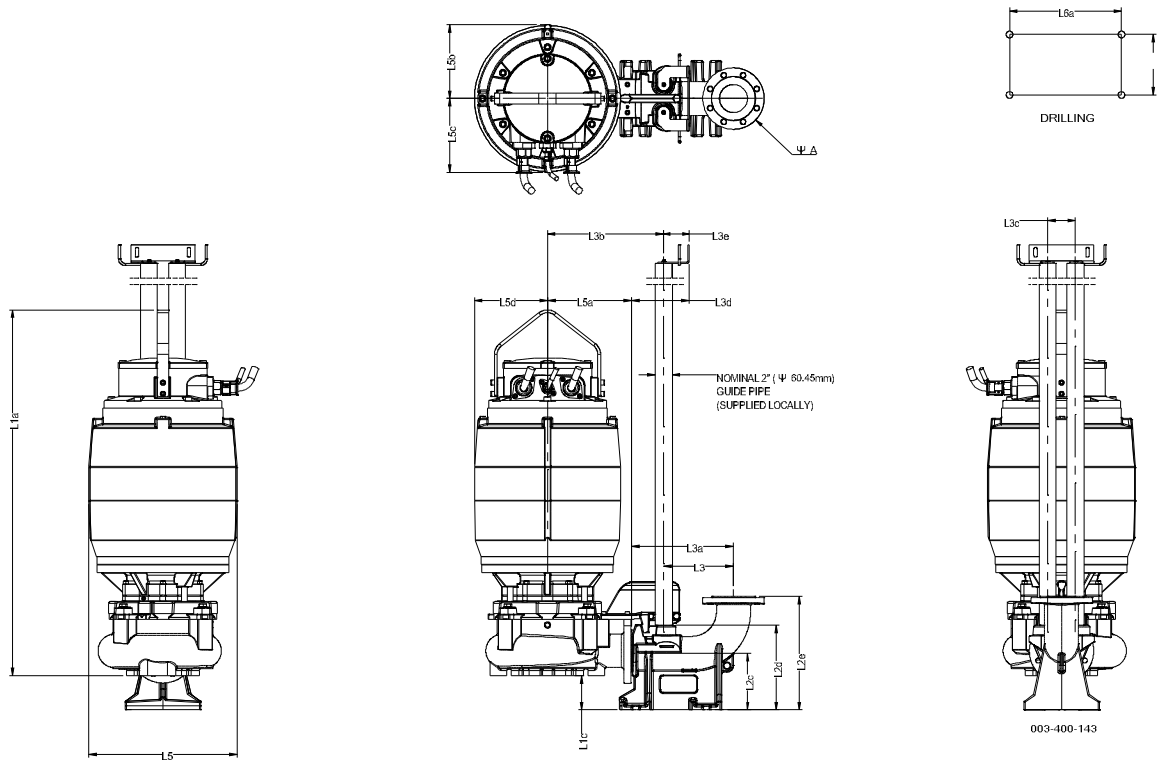

Dimensions		Dimensions	
Name	Value	Name	Value
L1a	1308	L5a	301
L1c	113	L5b	265
L2c	202	L5c	265
L2d	303	L5d	261
L2e	406	L6a	253
L3	249	L6b	140
L3a	364		
L3b	508		
L3c	100		
L3d	206		
L3e	91		
L5	530		

For Discharge connection bracket :

Outlet flange - Standard : DN100 / PN10- Option :4" ANSI class 125

For pump :

Outlet flange - Standard : DN100 / PN16 - Option :4" ANSI class 125

Suction flange - Standard : DN150 / PN16- Option :6" ANSI class 125

- Option : DN100 / PN16- Option :4" ANSI class 125

Weight of Pump with cooling jacket = 558 kg
 (without cooling jacket : - 132,7 kg)

Weight of Adapter = 10 kg

Weight of Discharge connection bracket (DCB) 100 = 47 kg

PX3-100.0-2 VORTEX 1 With motor M3.1E - 37

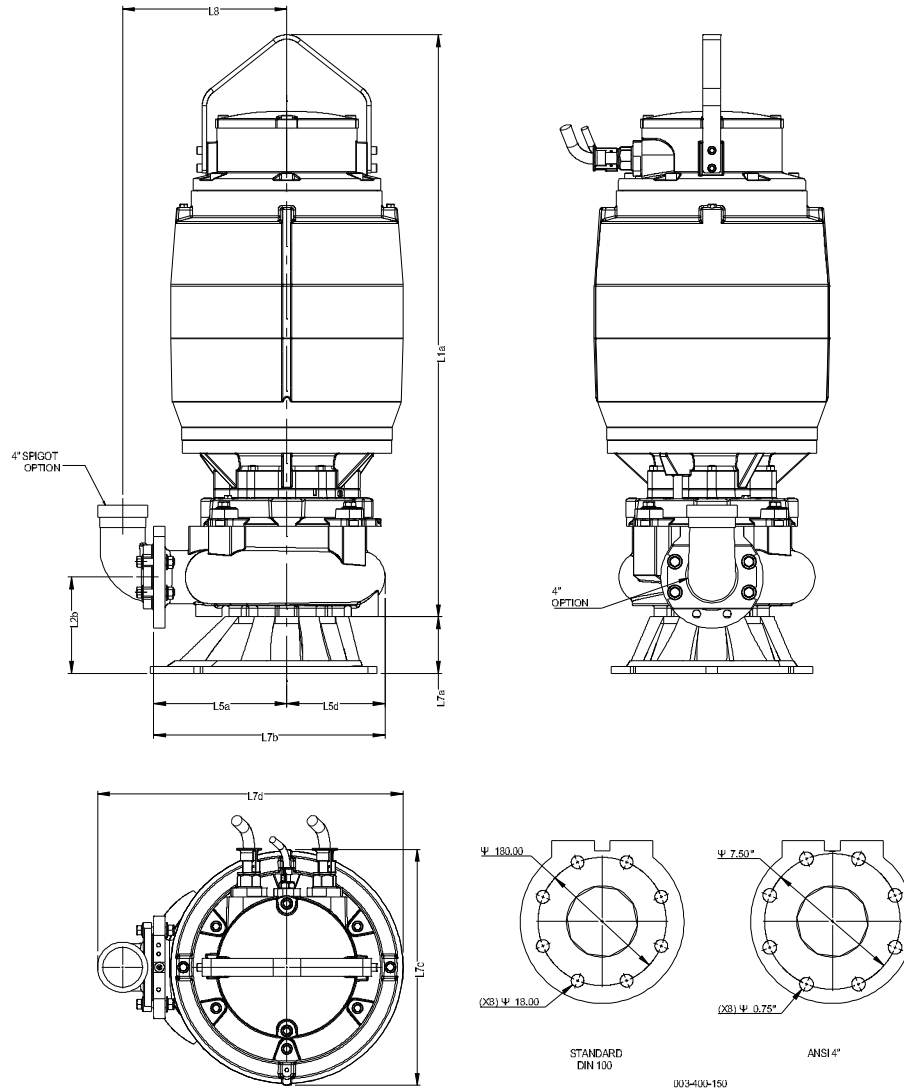

Dimensions		Dimensions			
Name	mm	Name	mm		
L1a	1308			Outlet for hose - Option : " 100mm (4")	
L1b	216,5			For pump :	
L5a	299,5			Outlet flange - Standard : DN100 / PN16	
L5d	221			- Option : 4" ANSI class 125	
L7a	127			Suction flange - Standard : DN150 / PN16	
L7b	520			- Option : 6" ANSI class 125	
L7c	530			- Option : DN100 / PN16	
L7d	687			- Option : 4" ANSI class 125	
L8	369			Weight of Pump with cooling jacket = 558 kg (without cooling jacket : - 132,7 kg)	
				Weight of Base for Transportable = 16,5 kg	

PX3-100.0-2 VORTEX 1 With motor M3.1E - 37

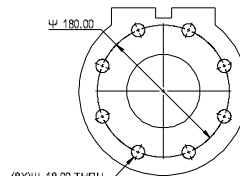
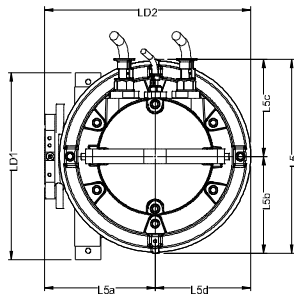
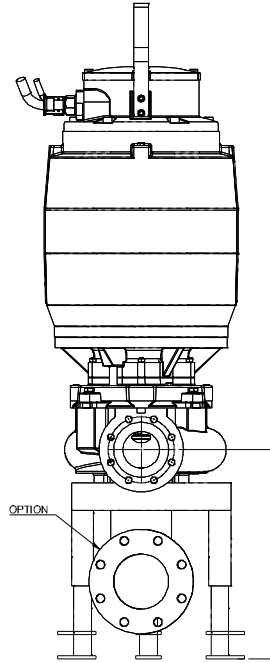
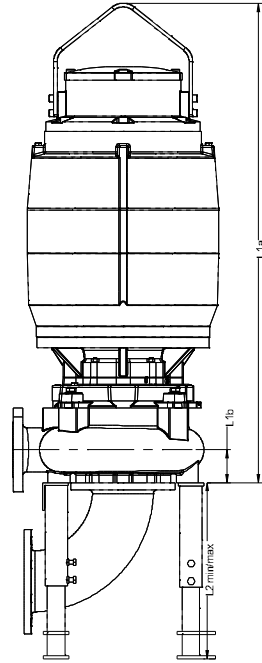

STANDARD
DIN 100

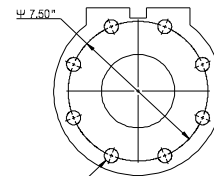

ANSI 4"

003-400-144

Dimensions	mm	Dimensions	mm
Name	Value	Name	Value
L1a	1308	LD2	562
L1b	90		
L2 max	481,5		
L2 min	415,5		
L2a max	570		
L2a min	505		
L5	530		
L5a	300		
L5b	265		
L5c	265		
L5d	226		
LD1	511		

Outlet flange - Standard : DN100 / PN16
- Option : 4" ANSI class 125

Suction flange - Standard : DN150 / PN16
- Option : 6" ANSI class 125
- Option : DN100 / PN16
- Option : 4" ANSI class 125

Weight of Pump with cooling jacket = 558 kg
Weight of Adjustable Legs = 15,2 kg

PX3-100.0-2 VORTEX 1 With motor M3.1E - 37

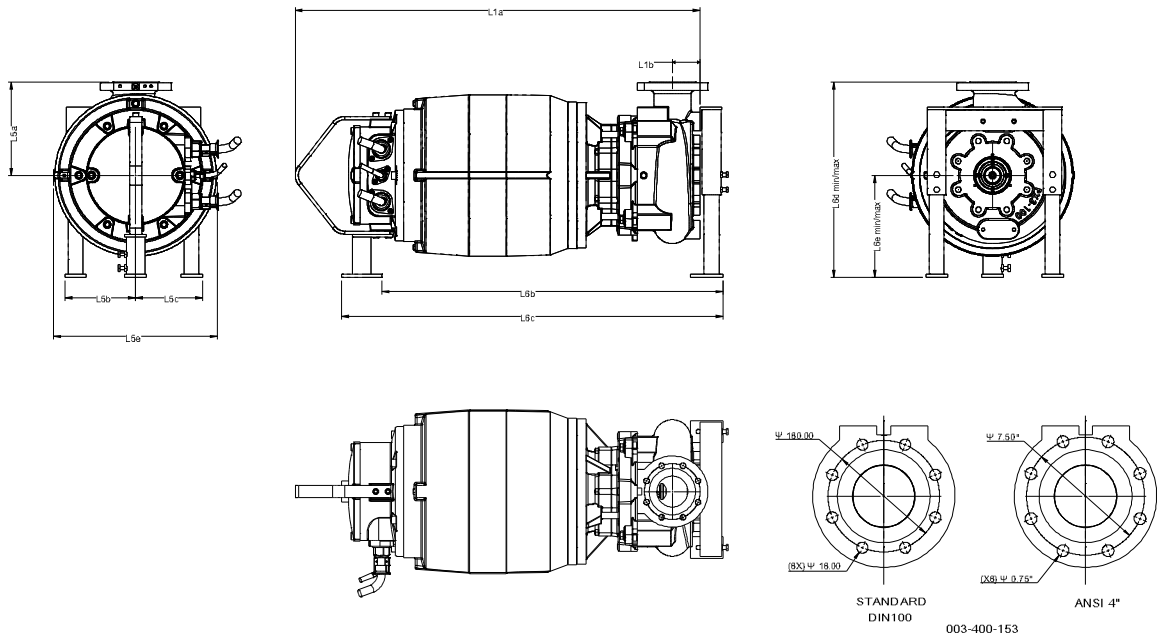

Dimensions	mm	Dimensions	mm	
Name	Value	Name	Value	
L1	1308			Outlet flange - Standard : DN100 / PN16 - Option : 4" ANSI class 125
L1b	90			
L5a	301			Suction flange - Standard : DN150 / PN16 - Option : 6" ANSI class 125 - Option : DN100 / PN16 - Option : 4" ANSI class 125
L5b	229			
L5c	216			
L5e	529			
L6b	1102			Weight of Pump with cooling jacket = 558 kg Weight of Adjustable Legs = 15,2 kg
L6c	1232			
L6dmax	671			
L6dmin	631			
L6emax	370			
L6emin	330			