

data referred to : Water; 20°C; 998,3kg/m³; 1,001mm²/s

Tolerances acc. ISO 9906 Grade 2B

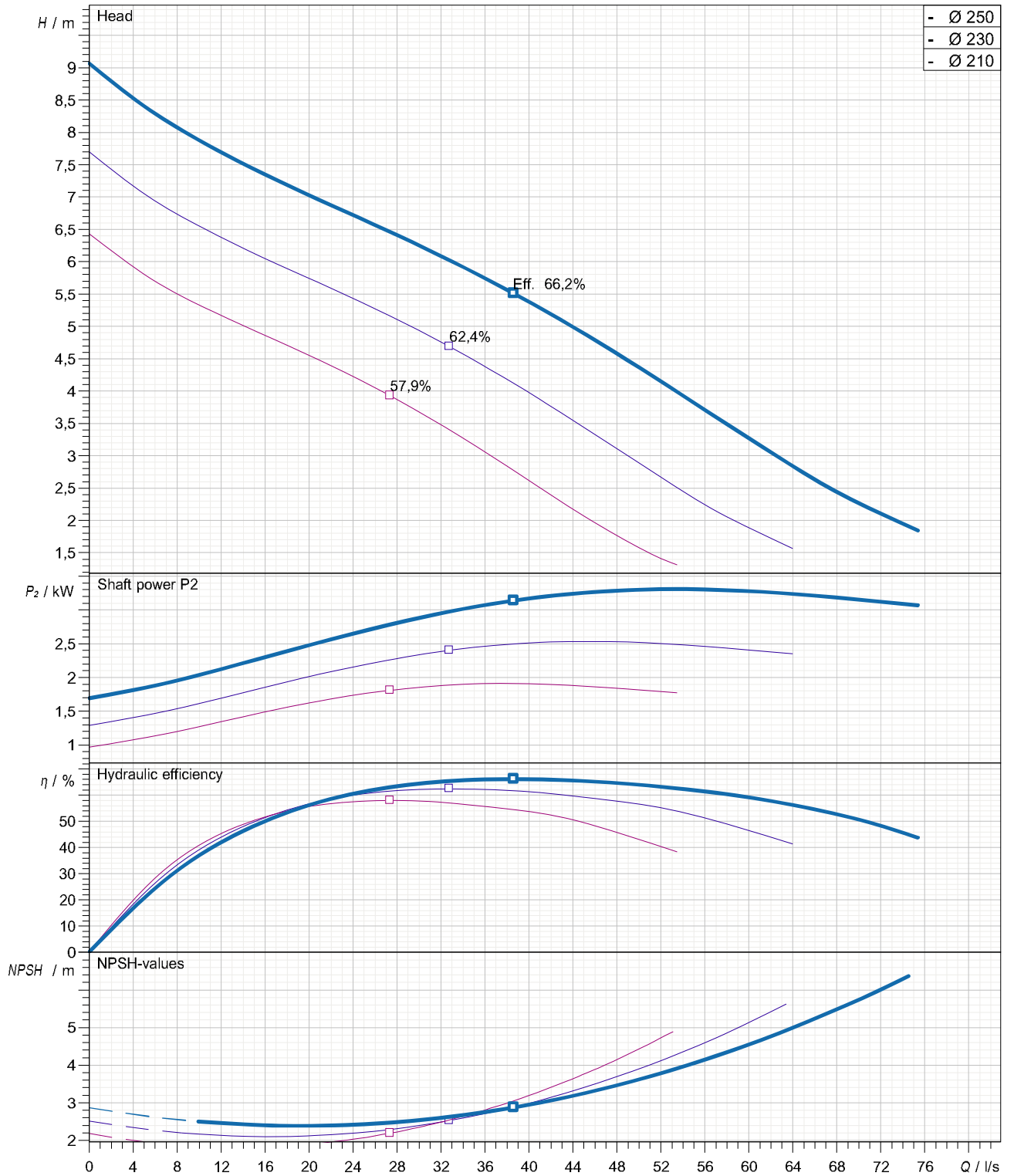

Curves are approximate, pump is guaranteed for one set of conditions (capacity, head, efficiency).

data referred to : Water; 20°C; 998,3kg/m³; 1,001mm²/s

Tolerances acc. ISO 9906 Grade 2B

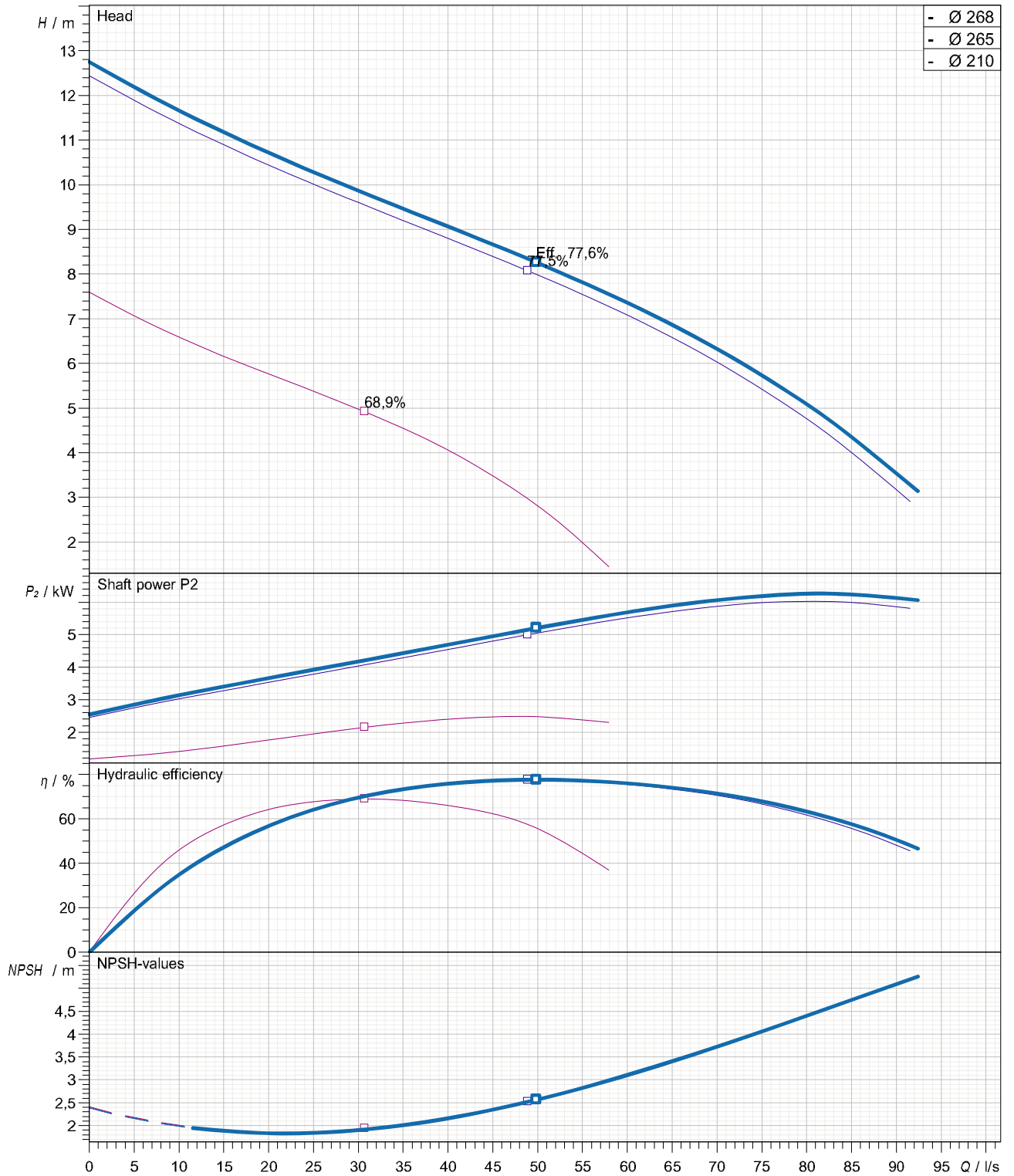

Curves are approximate, pump is guaranteed for one set of conditions (capacity, head, efficiency).

Submersible, centrifugal, non-clogging sewage pump PX2-150.0-6 CHANNEL 2 capable of handling raw, unscreened sewage.

The pumps manufactured within European Union with the latest manufacturing and environmental standards and practical standard features as :

- Dual channel impeller made in ductile iron GGG40 are of non clogging design
- Channel and vortex impellers can be accommodated in the same volute. This advance together with possibility to be trimmed allow to meet changing duties.
- Wear rings with 'reducer' clearances system allow to be re-positioned axially in order to reduce the clearances between the channel impeller and volute.
- Fast lock connection system latch bolts made in stainless steel for easy removal of the motor together with impeller from the volute.

Submersible motor type M2.1C- 7,5 IE2 can be capable of operating continuously in submerged for wet installation. Cooling jacket with Internal cooling system is available as option.

-Electrical motor PXFLOW -SIEMENS high efficiency class IE2 (premium efficiency IE3 as option) have Class F insulation (rated for 155 degrees Celsius) as standard (Class H as option)

-Separate sealed terminal connection area

-Rotor shaft oversized made in stainless steel and oversized ball bearings ensuring smooth and vibration free running with extended life time as result.

-Shaft sealing system consist of double mechanical seals built into a replaceable cartridge facilitate quick changes even on-site without special tools.

Motor protections :

- Three thermal overload switches, one per phase, internally wound to combat high temperature loads.
- Built-in moisture sensors to terminal connection area (upper motor side), inside the motor (lower side) and in oil chamber

Materials

PX2-150.0-6 CHANNEL 2 (Dual channel impeller) +7,5 kW

- Motor housing, volute : cast iron GG -25
- Impeller : ductile iron GGG40
- Shaft, cartridge sleeve : stainless steel 431
- Shaft seal: Media side sic/sic
Cooling side carbon/ceramic
- Bearings: upper: single row deep groove ball bearing
lower: double angular contact ball bearing

wet pit installation accessories set (on request)

- Discharge connection bracket (DCB): cast iron GG -25 (standard) or stainless steel (option)
- adapter : ductile iron GGG40 (standard) or stainless steel (option)
- Upper guide bracket (UGB): galvanized steel (standard) or stainless steel (option)

PX2-150.0-6 CHANNEL 2 With motor M2.1C-7,5 IE2

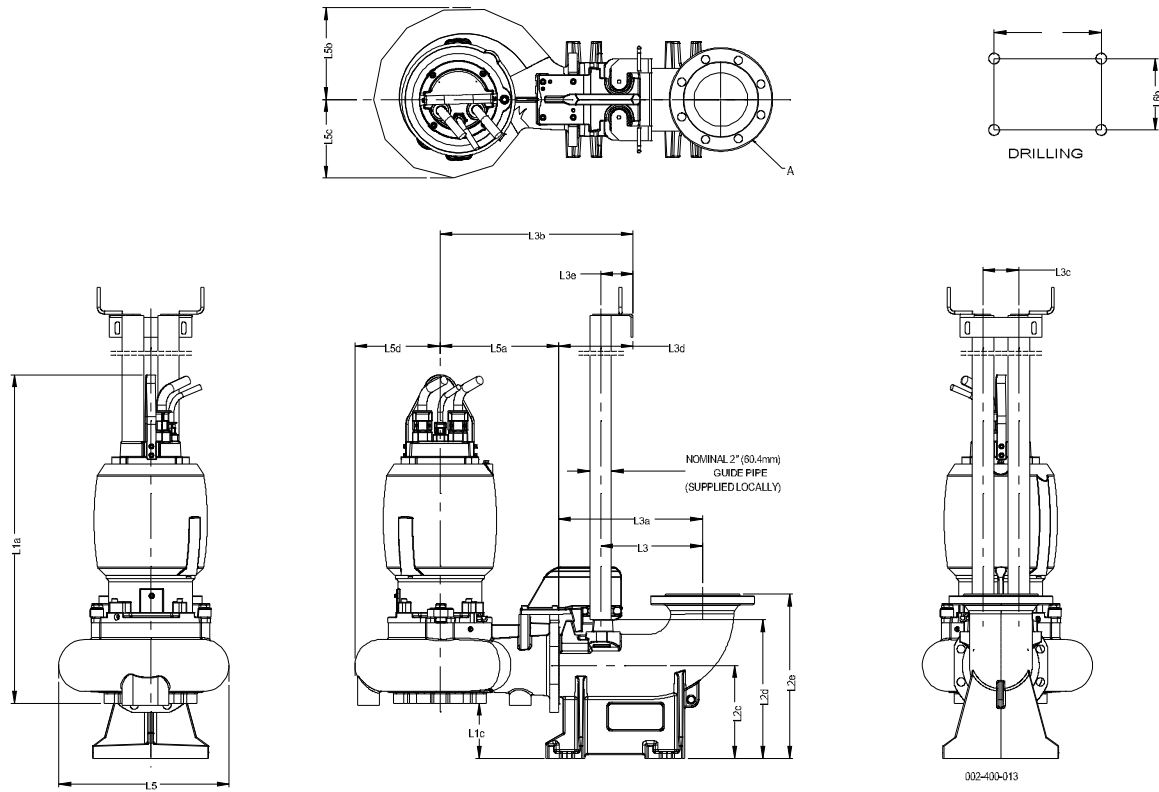

Dimensions		Dimensions			
Name	Value	Name	Value		
L1a	920	L5a	335	For Discharge connection bracket :	
L1c	155	L5b	257	Outlet flange - Standard : DN150 / PN10- Option : 6" ANSI class 125	
L2c	250	L5c	220	For pump :	
L2d	388,2	L5d	239	Outlet flange - Standard : DN150 / PN16- Option : 6" ANSI class 125	
L2e	460	L6a	280	Suction flange - Standard : DN150 / PN16- Option : 6" ANSI class 125	
L3	285	L6b	203,6	Weight of Pump with cooling jacket = 178 kg	
L3a (DN150)	400			(without cooling jacket : - 27 kg)	
L3b	540,5			Weight of Adapter = 10 kg	
L3c	100			Weight of Discharge connection bracket (DCB) 150 = 67 kg	
L3d	206				
L3e	91				
L5	477				

PX2-150.0-6 CHANNEL 2 With motor M2.1C-7,5 IE2

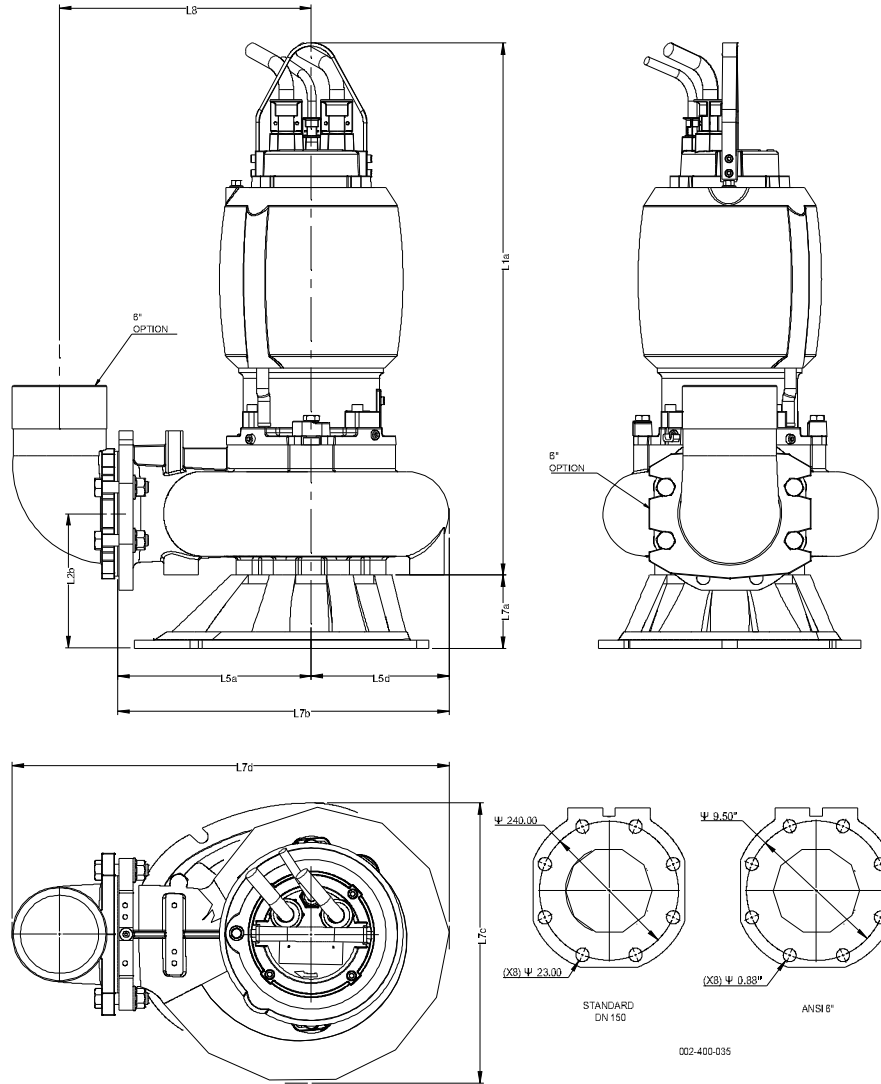

Dimensions		Dimensions	
Name	mm	Name	mm
L1	920		
L2b	232		
L5a	335		
L5d	239		
L7a	127		
L7b	573		
L7c	484		
L7d	755		
L8	335		

Outlet for hose - Option : " 150mm (6")

For pump :

Outlet flange - Standard : DN150 / PN16
- Option : 6" ANSI class 125

Suction flange - Standard : DN150 / PN16
- Option : 6" ANSI class 125

Weight of Pump with cooling jacket = 178 kg
(without cooling jacket : - 27 kg)

Weight of Base for Transportable = 16,5 kg

PX2-150.0-6 CHANNEL 2 With motor M2.1C-7,5 IE2

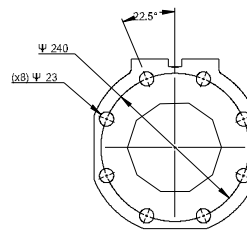
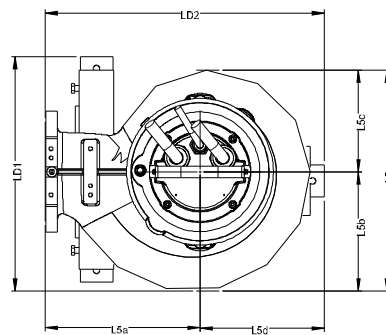
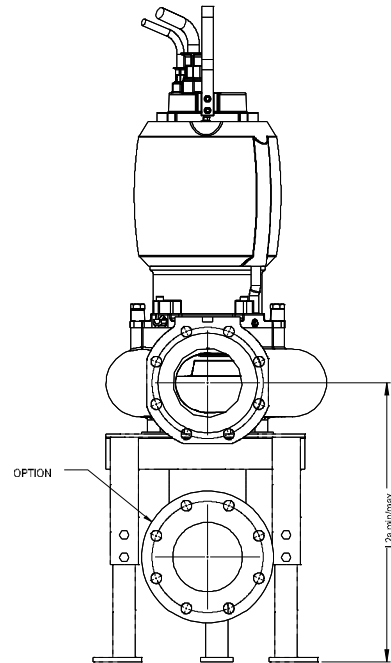
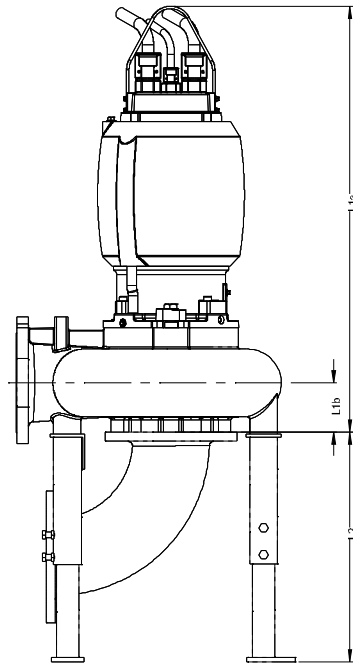

STANDARD
DIN 150

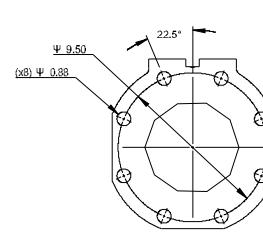

ANSI 6"
002-400-022

Dimensions	mm	Dimensions	mm
Name	Value	Name	Value
L1a	920	LD2	603
L1b	106		
L2amax	603		
L2amin	528		
L2max	500		
L2min	422		
L5	477		
L5a	335		
L5b	258		
L5c	220		
L5d	268		
LD1	506		

Outlet flange - Standard : DN150 / PN16
- Option : 6" ANSI class 125

Suction flange - Standard : DN150 / PN16
- Option : 6" ANSI class 125

Weight of Pump with cooling jacket = 178 kg
Weight of Adjustable Legs = 6,1 kg

PX2-150.0-6 CHANNEL 2 With motor M2.1C-7,5 IE2

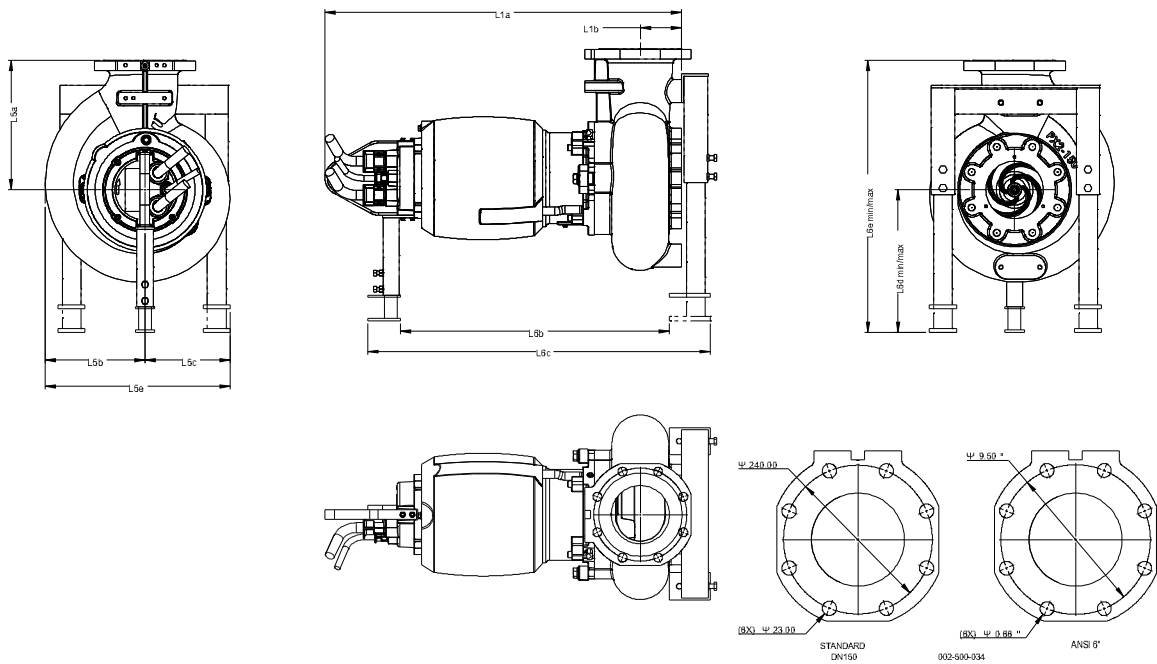

Dimensions	mm	Dimensions	mm
Name	Value	Name	Value
L1a	920	L6f	435
L1b	106		
L5a	335		
L5b	257		
L5c	220		
L5e	477		
L6b	694		
L6c	884		
L6dmax	368		
L6dmin	308		
L6emax	703		
L6emin	643		

Outlet flange - Standard : DN150 / PN16
 - Option : 6" ANSI class 125

Suction flange - Standard : DN150 / PN16
 - Option : 6" ANSI class 125

Weight of Pump with cooling jacket = 178 kg
 Weight of Adjustable Legs =