

data referred to Water; 20°C; 998,3kg/m³; 1,005mm²/s

Tolerances acc. ISO 9906 Grade 2B

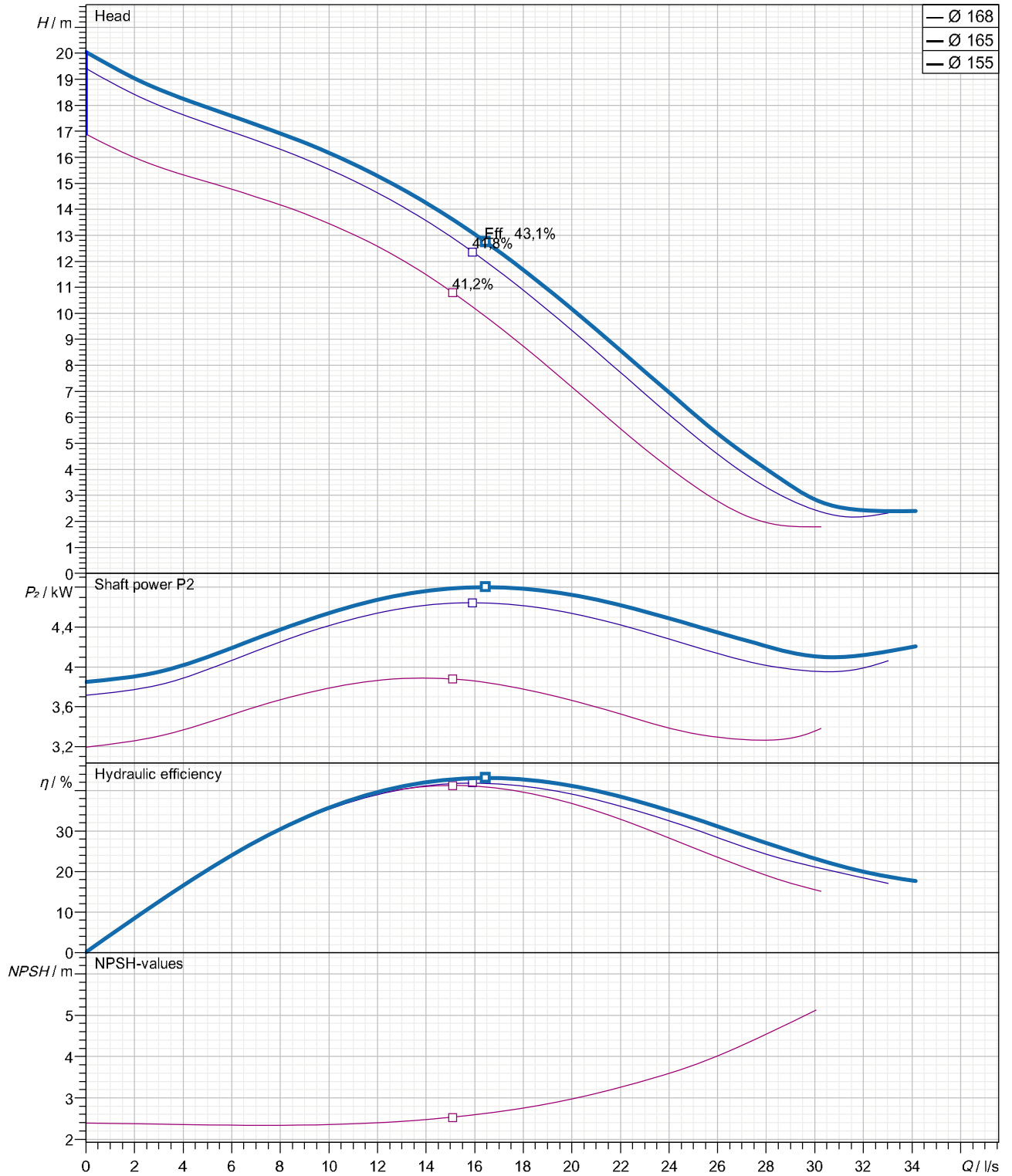

Curves are approximate, pump is guaranteed for one set of conditions (capacity, head, efficiency).

Submersible, centrifugal, non-clogging sewage pump PX1-80.0-2 VORTEX 2 capable of handling raw,unscreened sewage.

The pumps manufactured within European Union with the latest manufacturing and environmental standards and practical standard features as :

- Vortex impeller made in ductile iron GGG40 are of non clogging design
- Channel and vortex impellers can be accommodated in the same volute. This advance together with possibility to be trimmed allow to meet changing duties.
- Wear rings with 'reducer' clearances system allow to be re-positioned axially in order to reduce the clearances between the channel impeller and volute.
- Fast lock connection system latch bolts made in stainless steel for easy removal of the motor together with impeller from the volute.

Submersible motor type M1.1A- 5,0 can be capable of operating continuously in submerged for wet installation. Cooling jacket with Internal cooling system is available as option.

-Electrical motor PXFLOW -SIEMENS standard IE1 or higher efficiency class (IE2 or IE3 as option) have Class F insulation (rated for 155 degrees Celsius) as standard (Class H as option)

-Separate sealed terminal connection area

-Rotor shaft oversized made in stainless steel and oversized ball bearings ensuring smooth and vibration free running with extended life time as result.

-Shaft sealing system consist of double mechanical seals built into a replaceable cartridge facilitate quick changes even on-site without special tools.

Motor protections :

- Three thermal overload switches, one per phase, internally wound to combat high temperature loads.
- Built-in moisture sensors to terminal connection area (upper motor side), inside the motor (lower side) and in oil chamber

Materials

PX1-80.0-2 VORTEX 2 (Vortex impeller)+5 kW

-Motor housing, volute :cast iron GG -25

-Impeller : ductile iron GGG40

-Shaft, cartridge sleeve :stainless steel 431

-Shaft seal:Media side sic/sic

 Cooling side carbon/ceramic

-Bearings:upper:single row deep groove ball bearing

 lower: double angular contact ball bearing

wet pit installation accesories set (on request)

-Discharge connection bracket (DCB):cast iron GG -25 (standard) or stainless steel (option)

-adapter : ductile iron GGG40 (standard) or stainless steel (option)

-Upper guide bracket (UGB):galvanize steel (standard) or stainless steel (option)

PX1-80.0-2 VORTEX 2 With motor M1.1A-5,0

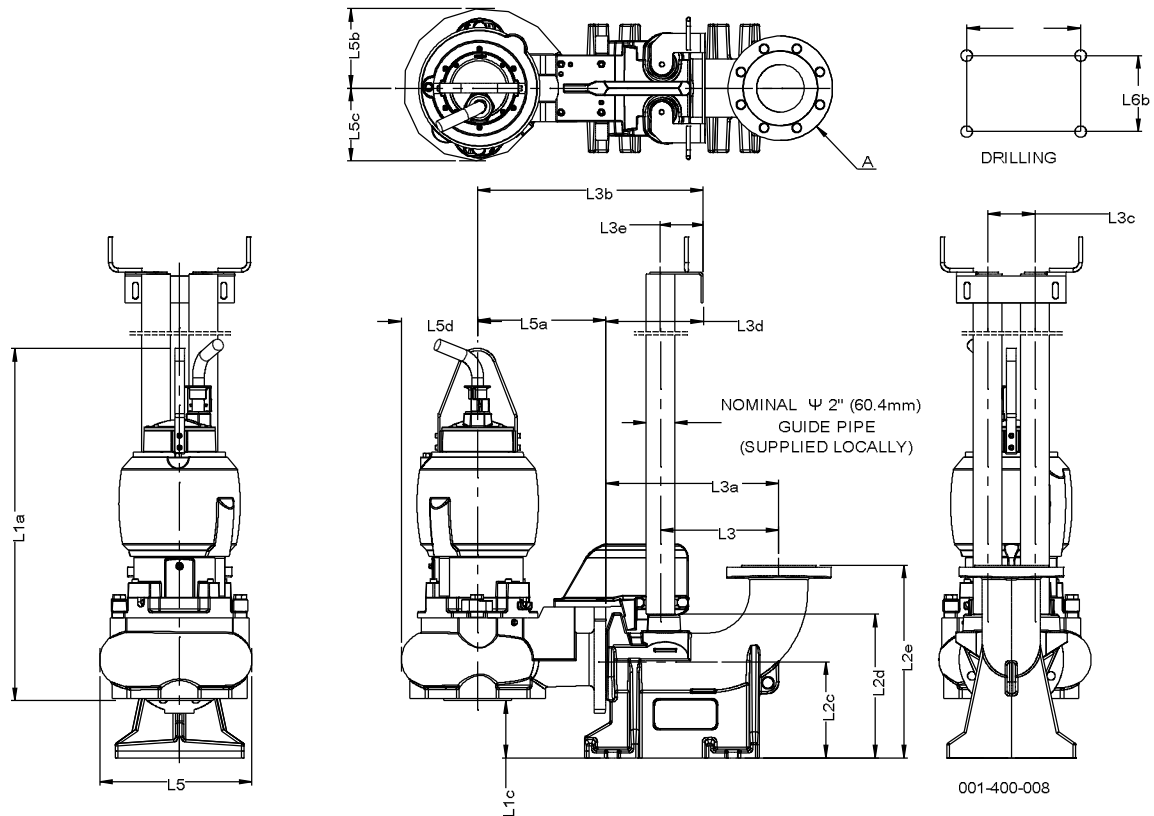

Dimensions mm		Dimensions mm		
Name	Value	Name	Value	
L1a	736,5	L5	320	For Discharge connection bracket : Outlet flange - Standard : DN100 / PN10 - Option: 4" ANSI class 125 - Option : DN80 / PN10 Flange ,3" ANSI class 125 For pump : Outlet flange - Standard :DN100 / PN10 - Option : 4" ANSI class 125 - Option : DN80 / PN10 ,3" ANSI class 125 Suction flange - Standard : DN100 / PN10 - Option : DN80 / PN10 - Option : 4" ANSI class 125 ,3" ANSI class 125 Weight of Pump with cooling jacket = 115 kg (without cooling jacket : - 14,2 kg) Weight of Adapter = 10 kg Weight of Discharge connection bracket (DCB) 100 = 47 kg Weight of Discharge connection bracket (DCB) 80 = 45 kg
L1c	121	L5a	270	
L2c	202	L5b	168,1	
L2d	303	L5c	152,6	
L2e	405,5	L5d	160	
L3	247	L6a	253	
L3a (DN100)	364	L6b	140	
L3a (DN80)	362			
L3b	475			
L3c	100			
L3d	206			
L3e	91			

PX1-80.0-2 VORTEX 2 With motor M1.1A-5,0

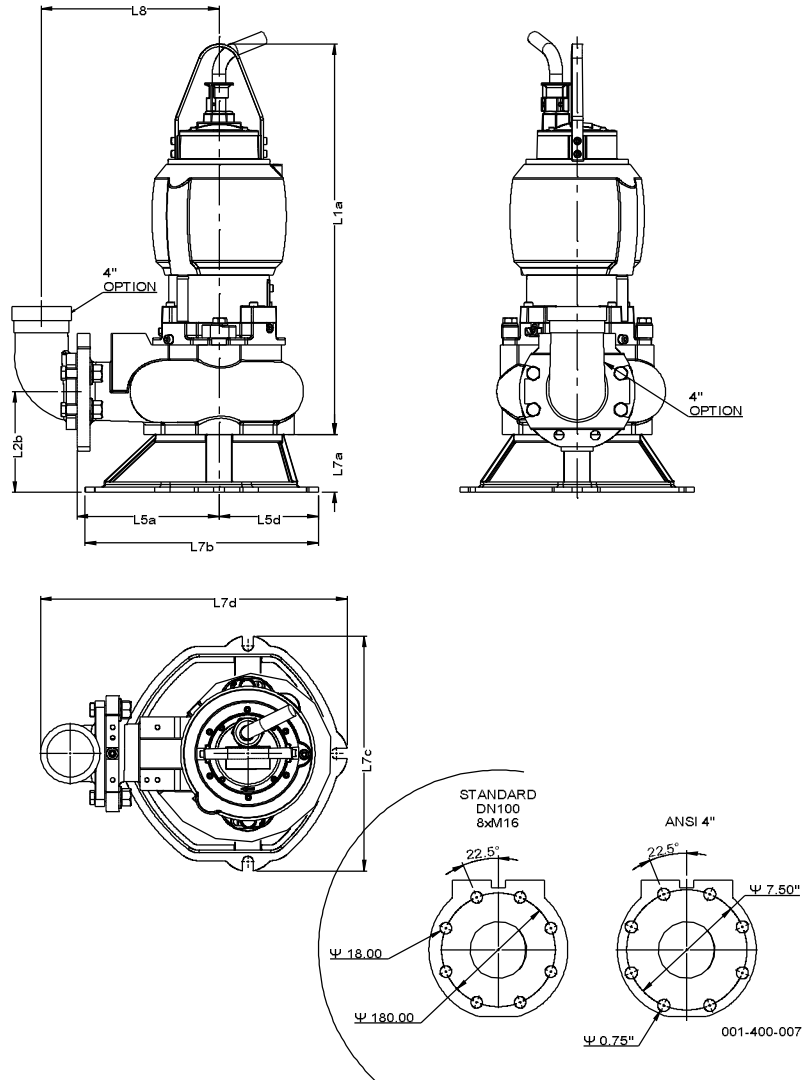

Dimensions mm		Dimensions mm	
Name	Value	Name	Value
L1a	736,5		
L2b	191,5		
L5a	270		
L5d	160		
L7a	110		
L7b	443		
L7c	446		
L7d	583		
L8	337,5		

Outlet for hose - Option : " 100mm (4")
Option : " 80mm (3")

For pump :

Outlet flange - Standard : DN100 / PN10 - Option : 4" ANSI class 125
- Option : DN80 / PN10 , 3" ANSI class 125

Suction flange - Standard : DN100 / PN10 - Option : 4" ANSI class 125
- Option : DN80 / PN10 , 4" ANSI class 125

Weight of Pump with cooling jacket = 113,7 kg
(without cooling jacket : - 14,2 kg)

Weight of Base for Transportable = 8,7 kg

PX1-80.0-2 VORTEX 2 With motor M1.1A-5,0

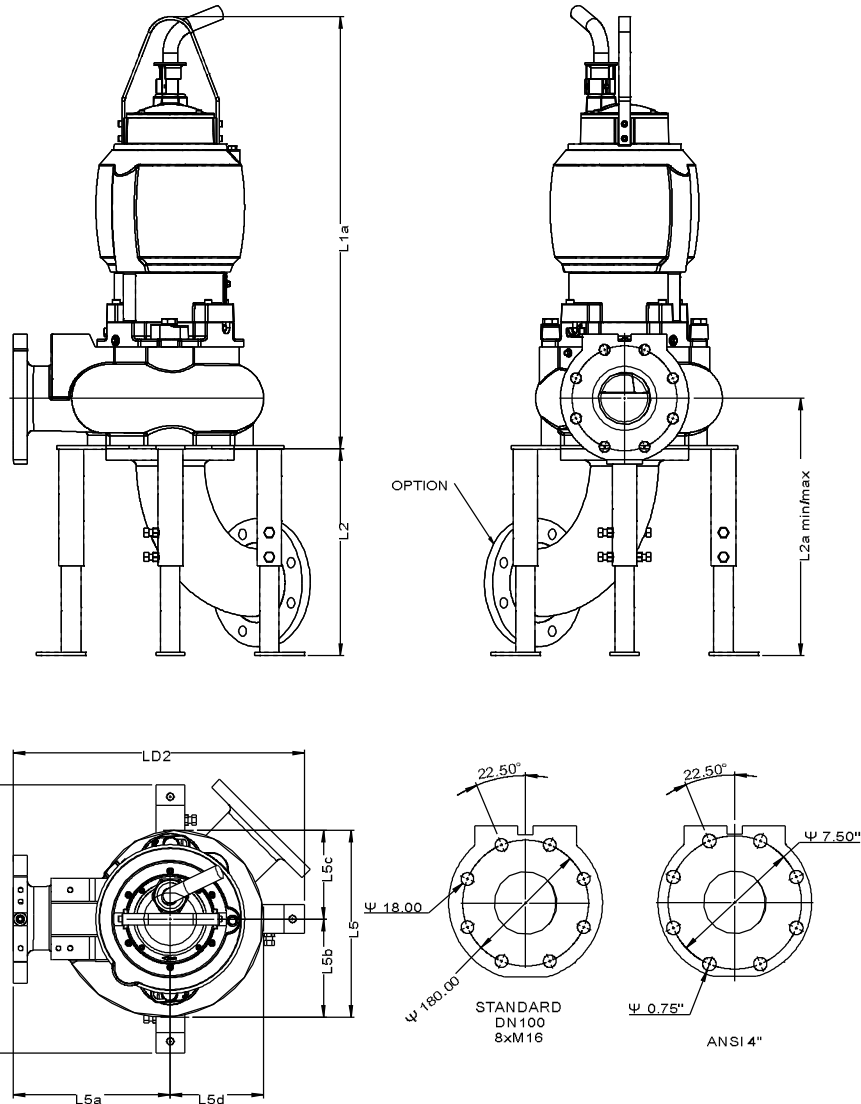

Dimensions	mm	Dimensions	mm	
Name	Value	Name	Value	
L1a	736,5	LD1	460	Outlet flange - Standard : DN100 / PN10 - Option : 4" ANSI class 125 - Option : DN80 / PN10 , 3" ANSI class 125
L1b	81,5	LD2	500	
L2 min	212			Suction flange - Standard : DN100 / PN10 - Option : 4" ANSI class 125 - Option : DN80 / PN10 , 3" ANSI class 125
L2a max	453			
L2a min	293			
L2max	360			
L3c	100			Total Weight of Pump =111,1 kg Weight of Adjustable Legs =6,1 kg
L5	320			
L5a	270			
L5b	168			
L5c	152			
L5d	160			

PX1-80.0-2 VORTEX 2 With motor M1.1A-5,0

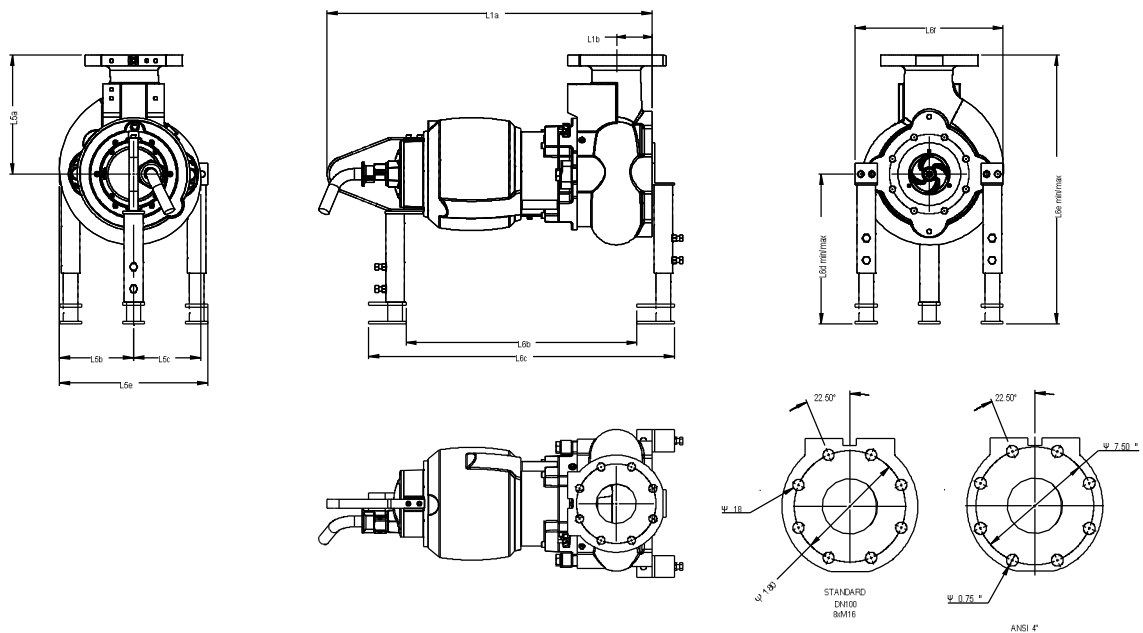

Dimensions	mm	Dimensions	mm	
Name	Value	Name	Value	Outlet flange - Standard : DN100 / PN10 - Option : 4" ANSI class 125 - Option : DN80 / PN10 , 3" ANSI class 125 Suction flange - Standard : DN100 / PN10 - Option : 4" ANSI class 125 - Option : DN80 / PN10 , 3" ANSI class 125 Total Weight of Pump =111,1 kg Weight of Adjustable Legs =6,1 kg
L1a	736,5	L6f	335	
L1b	80			
L5b	168,1			
L5c	152,6			
L5e	335			
L5a	270			
L6b	522,5			
L6c	692,5			
L6d max	339,5			
L6d min	301,5			
L6e max	609,5			
L6e min	571,5			